



## ULTRASONIC LIQUID LEVEL SWITCHES

Ultrasonic liquid level switches are used in a wide variety of applications to detect the location of level in a process or storage vessel. These switches can be used in virtually any liquid. A complete offering of materials and mounting configurations are available to meet your application needs.

### FEATURES

- No calibration necessary
- Remote Self-Test Feature
- No moving parts
- Vibration Resistant
- LED Relay Status Indicator
- Time Delay to avoid false trip

### APPLICATIONS:

- Solvents
- Water
- Acids
- Caustics
- Pump protection
- Compressors
- Storage Tanks
- Pipelines
- Paints
- Condensate
- Clean Liquids
- Crude Oil
- Boiler Water Cutoff
- Hydraulic Supply Lines
- Sewage Systems
- Food Processing
- Alkalies
- Alcohols
- Fuels
- Hydrocarbons

### INDUSTRIES

- Chemical
- Petroleum
- Water / Wastewater
- Pharmaceutical
- Pulp & Paper
- Power
- Aerospace

### PRINCIPLE OF OPERATION

Ultrasonic switches use piezoelectric crystals to transform electrical energy into mechanical motion (sound). The Transmit Crystal sends a pulse of sound through the space between the crystals to the Receive Crystal. If the space is filled with air, gas, or vacuum, the Receive Crystal does not detect the sound pulse. However, if the space is filled with liquid, the pulse is detected by the Receive Crystal and the switch output changes.

The KUST and KUSG ultrasonic switches have an electronics module mounted inside a NEMA 4/7 enclosure. The electronics module options are a 4-20mA current loop or a 10A DPDT relay. The 10A DPDT relay electronics module has a Fail-Safe two-position switch that allows the user to change the state of the internal relay, an LED Relay Status indicator that allows the user to visually observe the state of the relay, and a Self-Test push button to test the operation of the relay when no liquid is present. An Interface Gain Adjust is also provided for applications that require a reduction in the sensitivity of the ultrasonic sensor.

The KUSO ultrasonic switches are a low-cost alternative for applications not requiring hazardous area certification. With integrated electronics, it is a direct replacement for Float Switches, Capacitance and Optical Detectors.

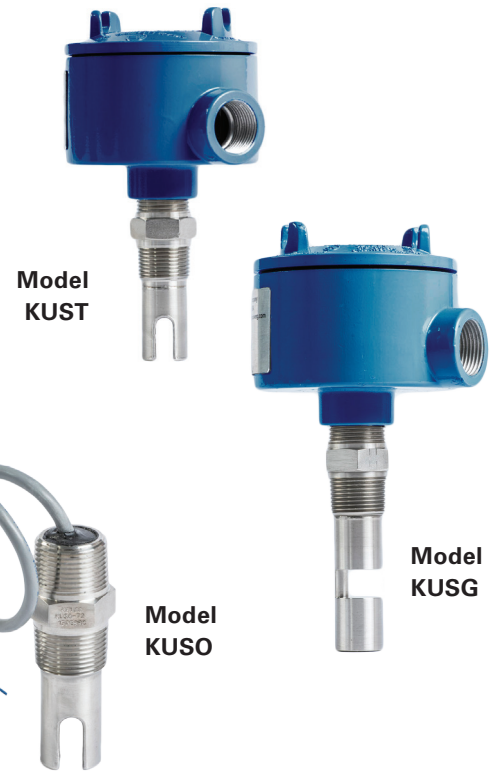

#### MODEL KUSG (Gap Style Probe)

Can be mounted vertically or horizontally. The larger crystals work well in liquids that attenuate sound and the large gap between the crystals is ideal for viscous liquids.

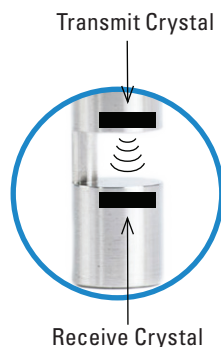

#### MODEL KUST / KUSO (Tip Style Probe)

Ideal for vertical installation in pipeline tees, tight spaces and applications where the switch actuation point needs to be at the lowest possible level.

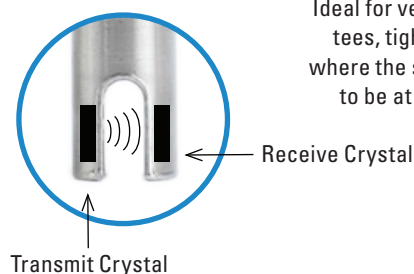

# PRODUCT SPECIFICATIONS

## MODEL KUST

DESCRIPTION		SPECIFICATIONS
Input Power	AC	90-240VAC
	DC	24VDC
	DC (Loop Power)	9-30VDC
Output	Relay	10A DPDT
	Loop Power	4-20mA
Temperature Range	Electronics	-20° F to 158° F (-28.9° C to 70° C)
	Sensor (316L Stainless Steel)	-4° F to 302° F (-20° C to 150° C)
	Sensor (CPVC)	32° F to 180° F (0° C to 82.2° C)
Pressure Range	316L Stainless Steel	Vacuum to 1000 PSIG
	CPVC	Vacuum to 150 PSIG
Sensitivity (Signal-to-Noise Ratio)		500:1 (Wet to Dry)
Repeatability		±0.079" (±2 mm)
Response Time		0.5 Second Fixed (Delay Available)

## MODEL KUSG

DESCRIPTION		SPECIFICATIONS
Input Power	AC	90-240VAC
	DC	24VDC
	DC (Loop Power)	9-30VDC
Output	Relay	10A DPDT
	Loop Power	4-20mA
Temperature Range	Electronics	-20° F to 158° F (-28.9° C to 70° C)
	Sensor (316L SS / Monel / Titanium)	-4° F to 350° F (-20° C to 176.7° C)
	Sensor (CPVC / Kynar)	32° F to 180° F (0° C to 82.2° C)
Pressure Range	316L Stainless Steel / Monel / Titanium	Vacuum to 1000 PSIG
	CPVC / Kynar	Vacuum to 150 PSIG
Sensitivity (Signal-to-Noise Ratio)		1000:1 (Wet to Dry)
Repeatability		±0.079" (±2 mm)
Response Time		0.5 Second Fixed (Delay Available)

## MODEL KUSO

DESCRIPTION		SPECIFICATIONS
Input Power	DC (Relay, Loop Power)	9-30VDC
Output	Relay	1A SPDT
	Loop Power	4-20mA
Temperature Range	Sensor	-4° F to 212° F (-20° C to 100° C)
Pressure Range	1/4" MNPT	Vacuum to 100 PSIG
	1/2" & 3/4" MNPT	Vacuum to 500 PSIG
Sensitivity (Signal-to-Noise Ratio)		500:1 (Wet to Dry)
Repeatability		±0.079" (±2 mm)
Response Time		0.5 Second Fixed (Delay Available)

## ORDERING GUIDES

REQUESTED BY: \_\_\_\_\_ COMPANY: \_\_\_\_\_

ADDRESS: \_\_\_\_\_ CITY: \_\_\_\_\_ STATE: \_\_\_\_\_ ZIP: \_\_\_\_\_

PHONE: \_\_\_\_\_ FAX: \_\_\_\_\_ EMAIL: \_\_\_\_\_

### MODEL KUSG / KUST

<input type="text"/>	<input type="text"/>	<input type="text"/>	<input type="text"/>	<input type="text"/>
<b>Switch Series</b> KUSG = Gap Style Probe KUST = Tip Style Probe	<b>Input Power</b> 1 = 90-240VAC 2 = 9-30VDC (Loop Power) 3 = 24VDC	<b>Output</b> 1 = 10A DPDT (Relay) 2 = 4-20mA (Loop Power)	<b>Switch Mounting</b> 1 = Integral 2 = Remote (In parenthesis, designate Cable Length in Feet)	<b>Sensor Material</b> S = 316L Stainless Steel P = CPVC K = Kynar (KUSG Only) M = Monel (KUSG Only) J = Titanium (KUSG Only)
<input type="text"/>	<input type="text"/>	<input type="text"/>	<input type="text"/>	
<b>Actuation Point</b> 00 = Standard (1.00" on KUSG) (1.25" on KUST) XX = Custom Length in Inches (Up to 99.00")	<b>*Process Connection</b> 1 = 3/4" MNPT F = 150 LB. R.F. ANSI Flange H = 300 LB. R.F. ANSI Flange J = 600 LB. R.F. ANSI Flange S = Sanitary Flange  <b>*Contact Kenco for other available connection types.</b>	<b>*Flange Size</b> Blank = None 0 = 1-1/2" 1 = 1" 2 = 2" 3 = 3"  <b>*Contact Kenco for other available flange sizes.</b>	<b>Flange Material</b> Blank = None A = Carbon Steel S = 316 Stainless Steel P = CPVC K = Kynar (KUSG Only) M = Monel (KUSG Only) J = Titanium (KUSG Only)	

• **Example Order Number:** KUST-3-2-1-S-00-1

### MODEL KUSO

<input type="text" value="KUSO"/>	<input type="text"/>	<input type="text" value="0"/>
<b>Switch Series</b> KUSO = Tip Style Probe with Connection Wires	<b>*Process Connection / Output</b> 0 = 1/4" MNPT / Loop Power, NPN & PNP 1 = 1/4" MNPT / 1A SPDT Relay 4 = 1/2" MNPT / Loop Power, NPN & PNP 5 = 1/2" MNPT / 1A SPDT Relay 6 = 3/4" MNPT / Loop Power, NPN & PNP 7 = 3/4" MNPT / 1A SPDT Relay	<b>Input Power</b> 0 = 9-30VDC Relay, Loop Power, NPN & PNP
<input type="text"/>	<input type="text"/>	
<b>Actuation Point</b> 00 = Standard (9/16" on 1/4" MNPT) (1-1/4" on 1/2" MNPT & 3/4" MNPT) XX = Custom Length in Inches (1/4" MNPT up to 36.00") (1/2" MNPT & 3/4" MNPT up to 96.00")	<b>Cable Length</b> 0 = Standard (1') XX = Custom Length in Feet	<b>*Process Connection Notes:</b> <ul style="list-style-type: none"> <li>• 1/4" MNPT probes are constructed from 316 stainless steel with an epoxy tip.</li> <li>• 1/2" MNPT &amp; 3/4" MNPT probes are constructed from 316 stainless steel.</li> <li>• Contact Kenco for other available connection types.</li> </ul>

• **Example Order Number:** KUSO-4-0-00-0

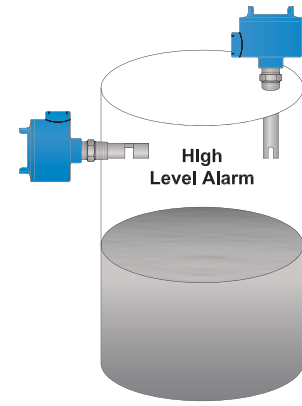
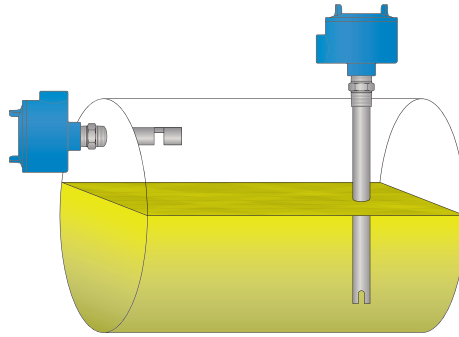
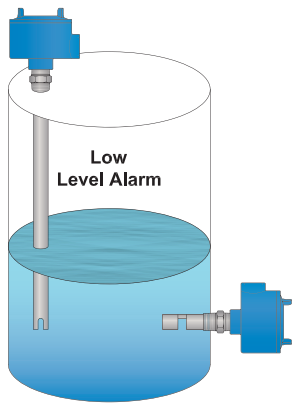

**Dimensional Note:** All dimensions are for reference purposes only and are subject to change at any time without notice.

### KUST

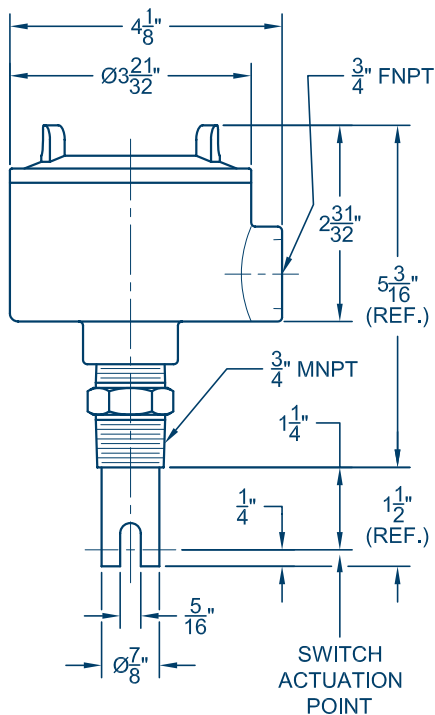

### KUST & KUSG

24VDC Input Power / 10ADPDT Output  
Electronics Module Shown

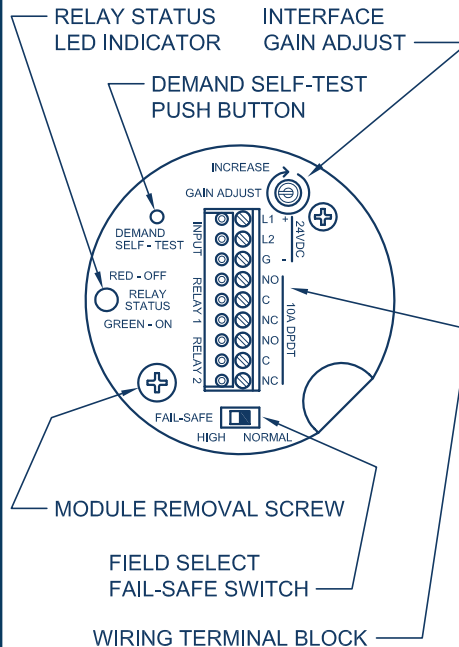

### KUSG

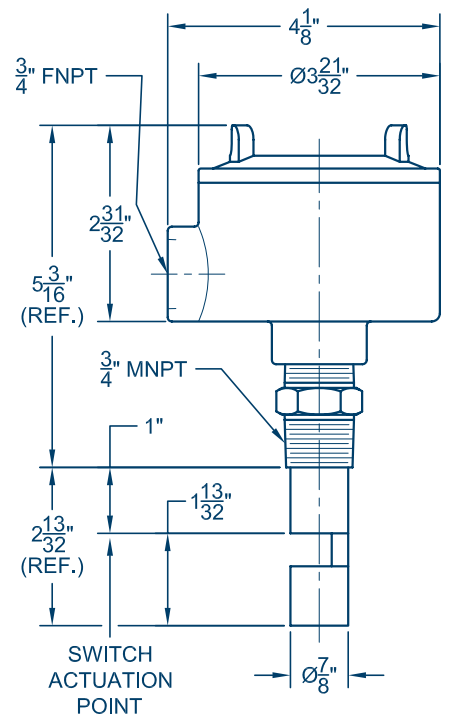

### KUSO-0 & KUSO-1

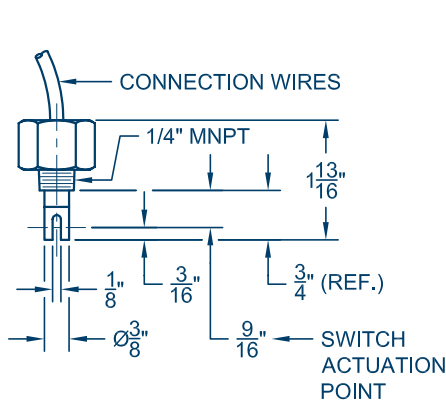

### KUSO-4 & KUSO-5

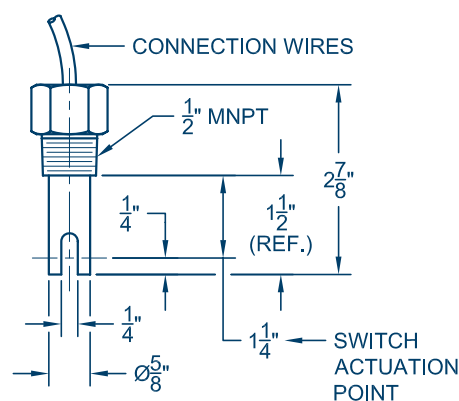

### KUSO-6 & KUSO-7

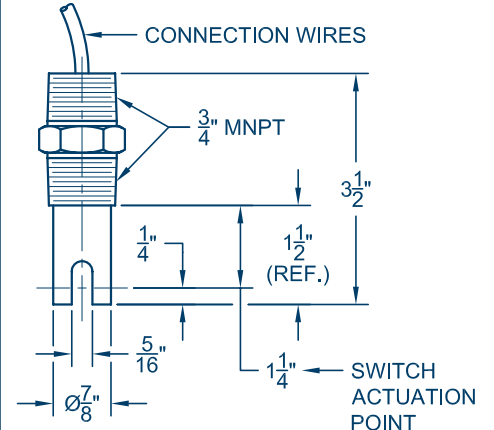

Represented by:

Kenco Sales Offices:

**Headquarters**

10001 E. 54th St.  
Tulsa, OK 74146  
phone 918.663.4406  
fax 918.663.4480  
www.kenco-eng.com  
email: info@kenco-eng.com

**Baton Rouge Office**

11616 Industriplex, Suite 7  
Baton Rouge, LA 70809  
phone 225.755.1912  
fax 225.755.1913  
www.kenco-eng.com  
email: kenco-la@kenco-eng.com

76649 2-7-18

