

GWC ITALIA

Proven technology
for individual valve solutions
worldwide



OIL PATCH FLOATING BALL VALVES

OBV-1001



GWC ITALIA

Worldwide Network

ITALY GROUP HEADQUARTERS, MANUFACTURING & SALES

GWC Italia S.p.A.
Via A. Grandi, 5
20056 Trezzo Sull'Adda
Milano, Italy
Phone: +39 02 86882941
Fax: +39 02 86882942
Email: sales@gwcitalia.com



**USA HEADQUARTERS
MANUFACTURING & SALES**
GWC Italia
8502 Crippen Street
Bakersfield, USA 93311
Phone: +1 661 834 1775
Fax: +1 661 834 2072
Email: sales@gwcitalia-usa.com



SALES DUBAI
GWC Italia DMCC
1506, Platinum Tower
I-Cluster,
Jumeirah Lake Towers
Dubai UAE
Phone: +971 44 539 358
Email: sales@gwcitalia.com



MANUFACTURING & SALES
GWC Valve Manufacturing
(Shanghai) Co., Ltd.
No 3300 Tianchen Road,
Qingpu, Shanghai 201708,
China
Phone: +86 21 5979 8796
Fax: +86 21 5979 8790
Email: sales@gwcitalia.com



SALES CHINA
GWC Italia
5/F, China Life Tower, No.16
Chaowai Street
Chaoyang District
Beijing 100020, China
Phone: +86 10 5877 1065
Fax: +86 10 5877 1120
Email: sales@gwcitalia.com

GWC Italia SpA with its Headquarters in Milan, Italy fully designs, manufactures and markets valves with one of the most extensive Trunnion Mounted Ball Valve lines you will find in the Industry today. GWC Italia which was founded by an Italian Group & USA Entrepreneurial Management team has a history of building and managing successful valve Manufacturing companies over the past 40 years. GWC Italia Valves are used in major applications for Upstream, Downstream & Transportation Segments of the Oil & Gas Industry, E&P, Petrochemical, Chemical, Mining/Minerals, Power, Marine and Industrial markets.

GWC Italia's extensive line of valve and flow control products include:

- Trunnion Mounted Ball Valves (soft & metal seated)
 - Split Body
 - Top Entry
 - Welded Body
 - Subsea
 - Cryogenic & High Temperature
 - Compact Body (Twin Ball)
- Floating Ball Valves
- Pipeline Gate and Check Valves
- Gate, Globe and Check Valves including Cast & Forged
- Needle & Gauge Valves



**Proven technology
for individual valve solutions
worldwide**

CERTIFICATIONS & STANDARDS

American Standards

American Petroleum Institute

API-6D	Specification for Pipeline Valves
API-6D SS	Specification for Subsea Pipeline Valves
API-6A	Specification for Wellhead and Christmas Tree Equipment
API-6FA	Specification for Fire Test for Valves
API-598	Valve Inspection and Testing
API-600	Bolted Bonnet Steel Gate Valves for Petroleum and Natural Gas Industries
API-602	Compact Steel Gate Valves-Flanged, Threaded, Welding and Extended-Body Ends
API-607	Fire Test for Soft-Seated Quarter-Turn Valves
API-608	Metal Ball Valves - Flanged, Threaded, and Welding End
API-Q1	Specification for Quality Programs for the Petroleum, Petrochemical & Natural Gas

International Standards

ISO 9001	Quality Management Systems
ISO 14001	Environmental Management
OHSAS 18001	Occupational Health and Safety Management System
ISO/TS 29001	Petroleum, Petrochemical and Natural Gas Industries - Sector Specific Quality Management Systems
CE/PED	Pressure Equipment Directive
TR CU	Technical Regulations of the Customs Union
CRN	Canadian Registration Number
Z245.15-17	Steel Valves
ATEX	European for explosive atmosphere
SIL3	Measurement of performance required for safety instrument function
ABS	American Bureau of Shipping



OIL PATCH FLOATING BALL VALVE - THREADED DESIGN

MAIN FEATURES

Series EW, EEW – Threaded Design

- Full port and Reduced port
- Two piece construction
- Fire safe design
- Anti-blow out Stem
- Excellent stem trunnion design with Two O-rings
- Stem lube fitting and weather seal
- Standard locking device configuration
- Stem Double-D design indicates ball open/closed position
- Conforms to NACE MR0175 Standard - Applicable for SS316 Trim
- Integration of relief hole in upstream for pressure equalization - Applicable for Freeze Resistant Ball Valve

COMMONLY USED APPLICATIONS

- Gas blowdown service
- Tank batteries for storage or production
- Production wing valves on low-pressure gas wells
- Production flow lines
- Production gathering systems for water, oil and gas



OIL PATCH FLOATING BALL VALVE - BOLTED DESIGN

MAIN FEATURES

Series EW, EEW – Bolted Design

- Full port and Reduced port
- Two piece construction
- Fire safe design
- Anti-blow out Stem
- Excellent stem trunnion design with Two O-rings
- Stem lube fitting and weather seal
- Standard locking device configuration
- Stem Double-D design indicates ball open/close position
- Conforms to NACE MR0175 Standard - Applicable for SS316 Trim
- Bolted body construction protects against end cap blowout

COMMONLY USED APPLICATIONS

- Gas blowdown service
- Tank batteries for storage or production
- Production wing valves on low-pressure gas wells
- Production flow lines
- Production gathering systems for water, oil and gas



ORDERING GUIDE

Example: 3” Figure # EW201-1-BC-G-L

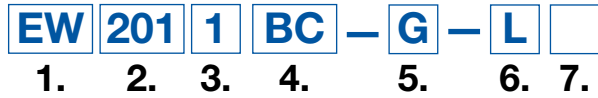

3” OIL PATCH DESIGN FULL PORT, 2000 WOG, FIRE SAFE DESIGN,
A216 WCB BODY x 316SS TRIM, RPTFE SEAT, LEVER OPERATOR.

1. MODEL

EW – OIL PATCH DESIGN FULL PORT

EEW – OIL PATCH DESIGN REDUCED PORT

2. RATING

071 – 750 WOG

101 – 1000 WOG

151 – 1500 WOG

201 – 2000 WOG

208 – 2000 WOG EUE API 5B 8RD

301 – 3000 WOG

308 – 3000 WOG EUE API 5B 8RD

368 – 3600 WOG EUE API 5B 8RD

501 – 5000 WOG

3. TYPE

1 – FIRE SAFE

4. MATERIAL (BODY + TRIM)

TB – DI + 420 SS

TC – DI + 316 SS

TD – DI-UNIDIRECTIONAL + 420 SS

TE – DI-UNIDIRECTIONAL + 316 SS

BB – WCB + 420 SS

BC – WCB + 316 SS

AB – A105N + 420 SS

AC – A105N + 316 SS

5. MATERIAL (SEAT)

G – RPTFE

J – DELRIN

V – PEEK

6. OPERATOR

L – HANDWHEEL OPERATOR

7. SPECIAL REQUIREMENTS

S – SUPPLY COMPLETE INFORMATION

DUCTILE IRON OIL PATCH BALL VALVE

Model EW, EEW Ductile Iron

SIZE RANGE : 1" - 4"
 PRESSURE : 750 PSI & 2000 PSI WOG
 TRIM : 316SS / 420SS [OPTION]
 OPERATOR : LEVER
 END CONNECTION : THREADED-NPT

- Full Port & Reduce Port
- Two-Piece Construction
- Fire Safe Design
- Excellent stem trunnion design with two O-rings
- Anti-Blow out Stem
- Standard locking Device configuration
- Stem lube fitting
- Double-D stem design
- Conforms to NACE MR-01-75 Standard
- Testing Standard: API 598
- Thread conform to: ASME B1.20.1 (NPT) API 5B (LP)



ITEM	PART NAME	MATERIAL
1	Body	ASTM A395 DI
2	Seat	RPTFE [1"-2"] / DELRIN [3"-4"]
3	Ball	316 SS [NACE] / 420 SS [NON-NACE]
4	Body O-Ring	HNBR
5	End Cap	ASTM A395 DI
6	Stem	"316 SS [NACE] / 420 SS [NON-NACE]"
7	Thrust Bearing	PTFE
8	Stem O-Ring	HNBR
9	Thrust Bearing	PTFE
10	Stop Plate	Carbon Steel
11	Retainer Ring	Carbon Spring Steel
12	Handle	Ductile Iron
13	Grease Fitting	Copper
14	Handle Bolt	Carbon Steel
15	Stopper	Carbon Steel
16*	Name Plate	Aluminium

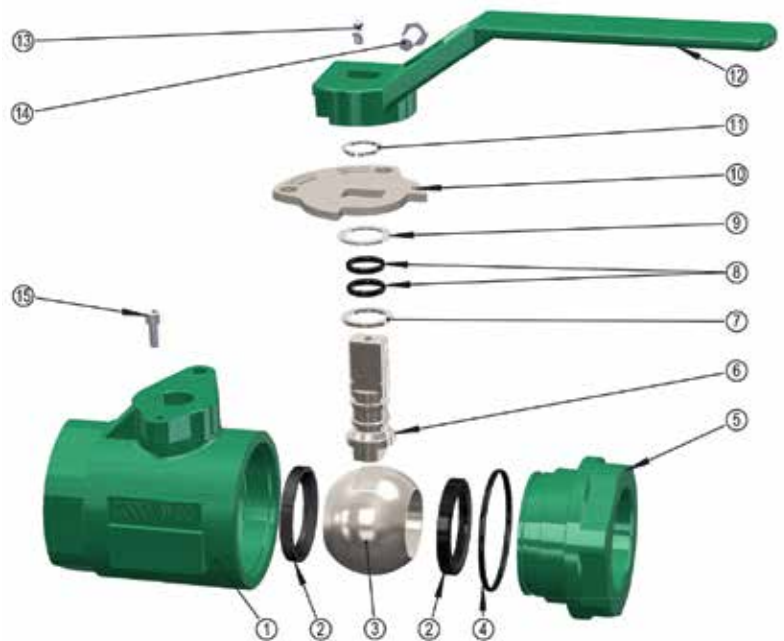

* Not shown on this view
 Note: All valves incorporating 316SS Trim conforms to NACE MR0175

MODEL: EW		FIGURE NO.		UNIT: INCH						
Size	Pressure	FIGURE NO.		L	H	NPT	d	W	Weight [Lbs]	
		NON-NACE	NACE							
1" x 1"	2000 PSI	EW201-1-TB-G-L	EW201-1-TC-G-L	4.0	3.7	1" - 11.5 NPT	1.0	6.3	4.4	
1-1/2" x 1-1/2"	2000 PSI	EW201-1-TB-G-L	EW201-1-TC-G-L	5.5	5.3	1.5" - 11.5 NPT	1.5	8.7	11.0	
2" x 2"	750 PSI	EW071-1-TB-G-L	EW071-1-TC-G-L	6.0	5.5	2" - 11.5 NPT	2.0	15.0	18.3	
2" x 2"	2000 PSI	EW201-1-TB-G-L	EW201-1-TC-G-L	6.0	5.5	2" - 11.5 NPT	2.0	15.0	18.3	
3" x 3"	750 PSI	EW071-1-TB-G-L	EW071-1-TC-G-L	8.7	6.9	3" - 8 NPT	3.0	15.0	44.0	
3" x 3"	1500 PSI	EW151-1-TB-J-L	EW151-1-TC-J-L	8.7	6.9	3" - 8 NPT	3.0	15.0	44.0	
4" x 4"	750 PSI	EW071-1-TB-G-L	EW071-1-TC-G-L	9.4	7.9	4" - 8 NPT	4.0	15.0	53.0	
4" x 4"	1000 PSI	EW101-1-TB-G-L	EW101-1-TC-G-L	9.4	7.9	4" - 8 NPT	4.0	15.0	53.0	

MODEL: EEW		FIGURE NO.		UNIT: INCH						
Size	Pressure	FIGURE NO.		L	H	NPT	d	W	Weight [Lbs]	
		NON-NACE	NACE							
2" x 1-1/2"	750 PSI	EEW071-1-TB-G-L	EEW071-1-TC-G-L	5.5	5.3	2" - 11.5 NPT	1.5	8.7	13.2	
2" x 1-1/2"	2000 PSI	EEW201-1-TB-G-L	EEW201-1-TC-G-L	5.5	5.3	2" - 11.5 NPT	1.5	8.7	13.2	
2-1/2" x 2"	2000 PSI	EEW201-1-TB-G-L	EEW201-1-TC-G-L	6.0	5.5	2.5" - 8 NPT	2.0	15.0	18.3	
3" x 2"	750 PSI	EEW071-1-TB-G-L	EEW071-1-TC-G-L	7.5	5.9	3" - 8 NPT	2.0	15.0	20.0	
3" x 2"	2000 PSI	EEW201-1-TB-G-L	EEW201-1-TC-G-L	7.5	5.9	3" - 8 NPT	2.0	15.0	20.0	
4" x 3"	750 PSI	EEW071-1-TB-G-L	EEW071-1-TC-G-L	8.7	7.2	4" - 8 NPT	3.0	15.0	44.0	
4" x 3"	1500 PSI	EEW151-1-TB-J-L	EEW151-1-TC-J-L	8.7	7.2	4" - 8 NPT	3.0	15.0	44.0	

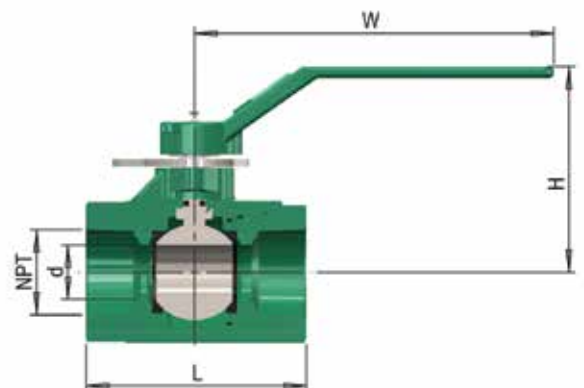

CARBON STEEL OIL PATCH BALL VALVE

Model EW, EEW Carbon Steel

SIZE RANGE : 1" - 4"
 PRESSURE : 1000PSI - 5000PSI WOG
 TRIM : 316SS / 420SS [OPTION]
 OPERATOR : LEVER
 END CONNECTION : THREADED-NPT

- Full Port & Reduce Port
- Two-Piece Construction
- Fire Safe Design
- Excellent Stem Journal design with two O-rings
- Anti-Blow out Stem
- Standard locking Device configuration
- Stem lube fitting
- Double-D stem design
- Conforms to NACE MR-01-75 Standard
- Testing Standard : API 598
- Thread conform to : ASME B1.20.1 (NPT) API 5B (LP)



ITEM	PART NAME	MATERIAL
1	Body	ASTM A216 WCB
2	Seat	RPTFE : 1500-2500 PSI DELTRIN : 3000 PSI PEEK : 5000 PSI
3	Ball	316 SS [NACE] /420 SS [NON-NACE]
4	Body O-Ring	HNBR
5	End Cap	ASTM A216 WCB
6	Stem	316 SS [NACE] /420 SS [NON-NACE]
7	Thrust Bearing	PTFE
8	Stem O-Ring	HNBR
9	Thrust Bearing	PTFE
10	Stop Plate	Carbon Steel
11	Retainer Ring	Carbon Spring Steel
12	Handle	Ductile Iron
13	Grease Fitting	Copper
14	Handle Bolt	Carbon Steel
15	Stopper	Carbon Steel
16*	Name Plate	Aluminium

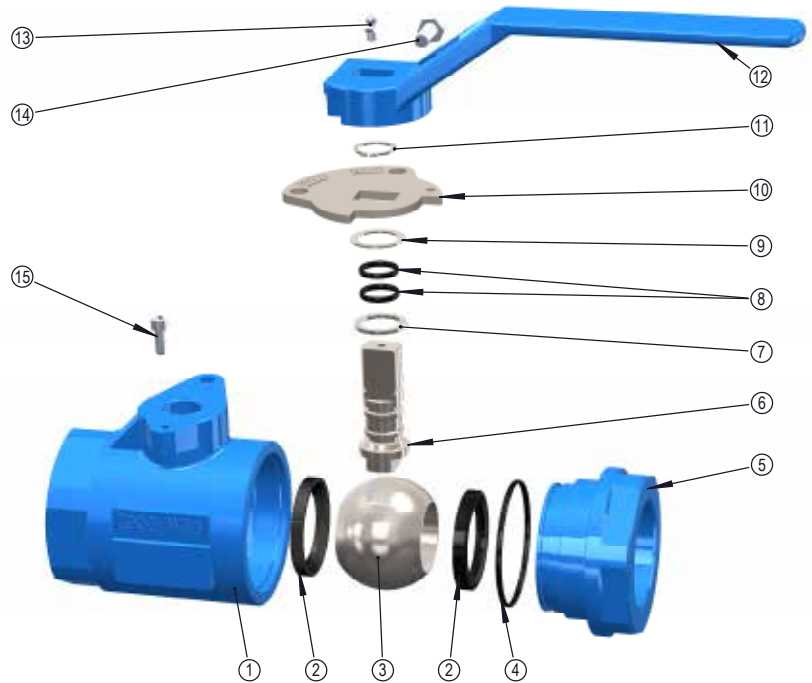

* Not shown on this view
 Note: All valves incorporating 316SS
 Trim conforms to NACE MR0175

MODEL: EW		UNIT: INCH							
Size	Pressure	FIGURE NO.		L	H	NPT	d	W	Weight [Lbs]
		NON-NACE	NACE						
1" X 1"	3000 WOG	EW301-1-BB-J-L	EW301-1-BC-J-L	4.0	3.7	1" - 11.5 NPT	1.0	6.3	4.8
1" X 1"	5000 WOG	EW501-1-BB-V-L	EW501-1-BC-V-L	4.0	3.7	1" - 11.5 NPT	1.0	6.3	4.8
1-1/2" X 1-1/2"	3000 WOG	EW301-1-BB-J-L	EW301-1-BC-J-L	5.5	5.3	1.5" - 11.5 NPT	1.5	8.7	13.2
1-1/2" X 1-1/2"	5000 WOG	EW501-1-BB-V-L	EW501-1-BC-V-L	5.5	5.3	1.5" - 11.5 NPT	1.5	8.7	13.2
2" X 2"	3000 WOG	EW301-1-BB-J-L	EW301-1-BC-J-L	6.0	5.9	2" - 11.5 NPT	2.0	15.0	18.7
2" X 2"	5000 WOG	EW501-1-BB-V-L	EW501-1-BC-V-L	6.0	5.9	2" - 11.5 NPT	2.0	15.0	18.7
3" X 3"	2000 WOG	EW201-1-BB-G-L	EW201-1-BC-G-L	8.7	6.8	3" - 8 NPT	3.0	15.0	53.0
3" X 3"	3000 WOG	EW301-1-BB-J-L	EW301-1-BC-J-L	8.7	6.8	3" - 8 NPT	3.0	15.0	53.0

MODEL: EEW		UNIT: INCH							
Size	Pressure	FIGURE NO.		L	H	NPT	d	W	Weight [Lbs]
		NON-NACE	NACE						
2" X 1-1/2"	3000 WOG	EEW301-1-BB-J-L	EEW301-1-BC-J-L	5.5	5.3	2" - 11.5 NPT	1.5	8.7	13.2
2" X 1-1/2"	5000 WOG	EEW501-1-BB-V-L	EEW501-1-BC-V-L	5.5	5.3	2" - 11.5 NPT	1.5	8.7	13.2
2-1/2" X 2"	3000 WOG	EEW301-1-BB-J-L	EEW301-1-BC-J-L	6.0	5.9	2.5" - 8 NPT	2.0	15.0	18.7
2-1/2" X 2"	5000 WOG	EEW501-1-BB-V-L	EEW501-1-BC-V-L	6.0	5.9	2.5" - 8 NPT	2.0	15.0	18.7
3" X 2"	3000 WOG	EEW301-1-BB-J-L	EEW301-1-BC-J-L	6.0	5.9	2.5" - 8 NPT	2.0	15.0	18.7
4" X 3"	1000 WOG	EEW101-1-BB-G-L	EEW101-1-BC-G-L	8.7	6.8	4" - 8 NPT	3.0	15.0	53.0
4" X 3"	1500 WOG	EEW151-1-BB-G-L	EEW151-1-BC-G-L	8.7	6.8	4" - 8 NPT	3.0	15.0	53.0

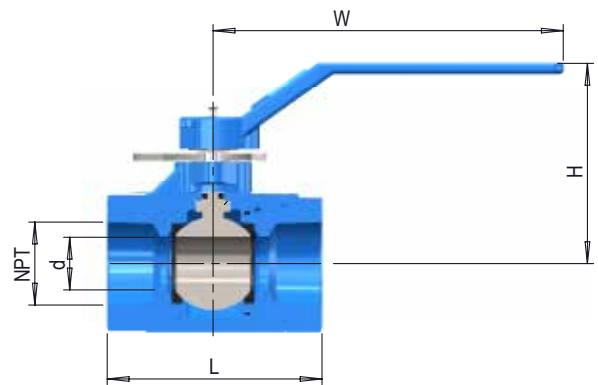

8RD EUE OIL PATCH BALL VALVE

Model 8RD EUE Carbon Steel

SIZE RANGE :
 2-3/8" EUE X 2-1/16 BORE
 2-7/8" EUE X 2-9/16 BORE
 PRESSURE : 2000/ 3000/ 3600 PSI WOG
 TRIM : 316SS / 420SS [OPTION]
 OPERATOR : LEVER



- Reduce Port
- Two-Piece Construction
- Fire Safe Design
- Excellent Stem Journal design with two O-rings
- Anti-Blow out Stem
- Standard locking Device configuration
- Stem lube fitting
- Double-D stem design
- Conforms to NACE MR-01-75 Standard
- Testing Standard : API 598
- Thread conform to : API 5B 8RD

ITEM	PART NAME	MATERIAL
1	Body	ASTM A216 WCB
2	Seat	DELTRIN
3	Ball	316 SS [NACE] /420 SS [NON-NACE]
4	Body O-Ring	HNBR
5	End Cap	ASTM A216 WCB
6	Stem	316 SS [NACE] /420 SS [NON-NACE]
7	Thrust Bearing	PTFE
8	Stem O-Ring	HNBR
9	Thrust Bearing	PTFE
10	Stop Plate	Carbon Steel
11	Retainer Ring	Carbon Spring Steel
12	Handle	Ductile Iron
13	Grease Fitting	Copper
14	Handle Bolt	Carbon Steel
15	Stopper	Carbon Steel
16*	Name Plate	Aluminum

* Not shown on this view
 Note: All valves incorporating 316SS
 Trim conforms to NACE MR0175

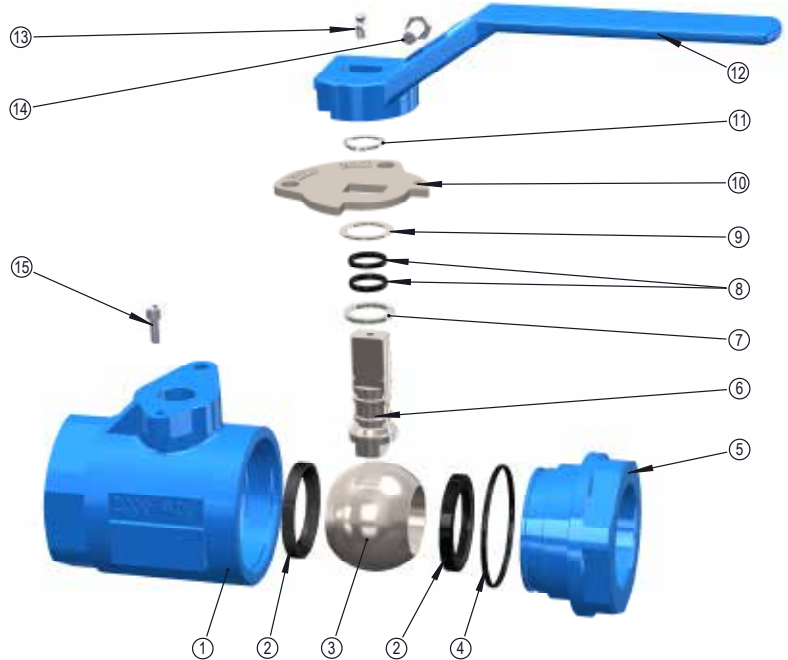

MODEL: 8RD EUE		UNIT: INCH								
Size	Pressure	FIGURE NO.		L	H	NPT	d	W	Weight [Lbs]	
		NON-NACE	NACE							
2-3/8" X 2-3/8"	2000 WOG	EW208-1-BB-J-L	EW208-1-BC-J-L	8.5	6.1	2-3/8" EUE	2.0	15.0	28.2	
2-3/8" X 2-3/8"	3000 WOG	EW308-1-BB-J-L	EW308-1-BC-J-L	8.5	6.1	2-3/8" EUE	2.0	15.0	28.2	
2-3/8" X 2-3/8"	3600 WOG	EW368-1-BB-J-L	EW368-1-BC-J-L	8.5	6.1	2-3/8" EUE	2.0	15.0	28.2	
2-7/8" X 2-7/8"	2000 WOG	EW208-1-BB-J-L	EW208-1-BC-J-L	9.5	6.9	2-7/8" EUE	2.6	15.0	44.1	
2-7/8" X 2-7/8"	3000 WOG	EW308-1-BB-J-L	EW308-1-BC-J-L	9.5	6.9	2-7/8" EUE	2.6	15.0	44.1	
2-7/8" X 2-7/8"	3600 WOG	EW368-1-BB-J-L	EW368-1-BC-J-L	9.5	6.9	2-7/8" EUE	2.6	15.0	44.1	

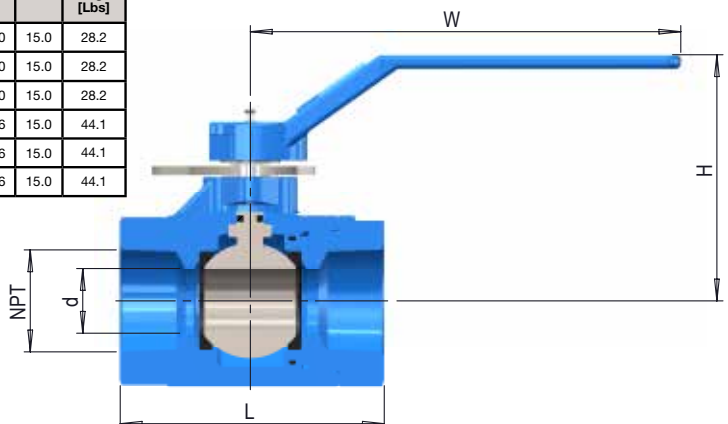

FREEZE RESISTANT OIL PATCH BALL VALVE

Model EEW Ductile Iron

SIZE RANGE : 2" - 4"
 PRESSURE : 750PSI WOG
 TRIM : 316SS / 420SS [OPTION]
 OPERATOR : LEVER
 END CONNECTION : THREADED-NPT

- Reduce Port
- Unidirectional
- Two-Piece Construction
- Fire Safe Design
- Excellent Stem Journal design with two O-rings
- Anti-Blow out Stem
- Standard locking Device configuration
- Integration of relief hole in the upstream side
- Double-D stem design
- Weather Seal
- Conforms to NACE MR-01-75 Standard
- Testing Standard: API 598
- Thread conform to: ASME B1.20.1 (NPT)

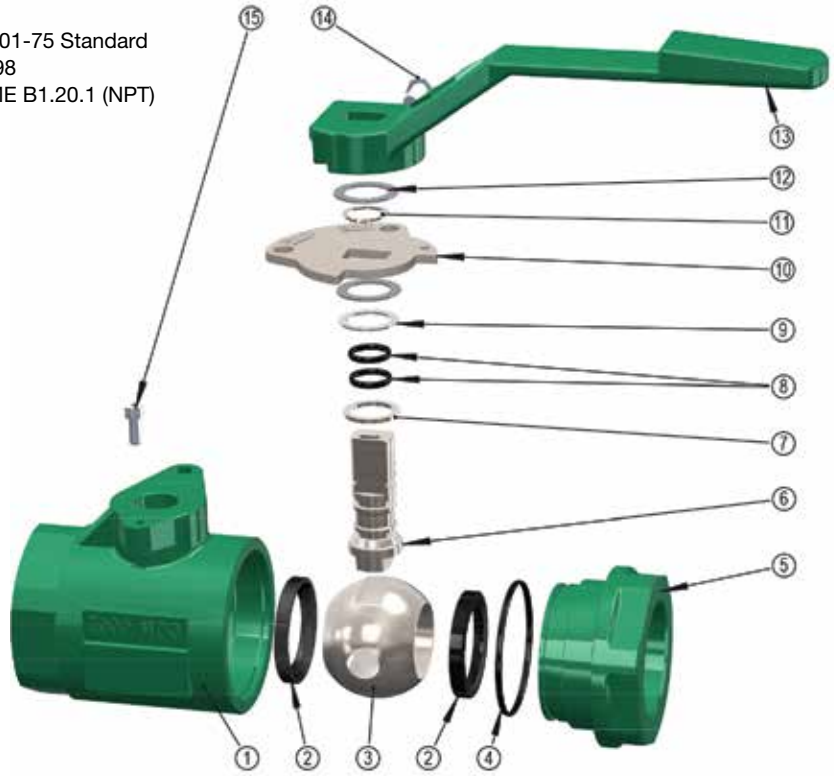

ITEM	PART NAME	MATERIAL
1	Body	ASTM A395 DI
2	Seat	RPTFE
3	Ball	316 SS [NACE] /420 SS [NON-NACE]
4	Body O-Ring	HNBR
5	End Cap	ASTM A395 DI
6	Stem	316 SS [NACE] /420 SS [NON-NACE]
7	Stem Gasket	PTFE
8	Stem O-Ring	HNBR
9	Gasket	PTFE
10	Stop Plate	Carbon Steel
11	Retainer Ring	Carbon Spring Steel
12	Protective Weather Guard	PVC
13	Handle	Ductile Iron
14	Handle Bolt	Carbon Steel
15	Stopper	Carbon Steel
16*	Name Plate	Aluminium

* Not shown on this view
 Note: All valves incorporating 316SS
 Trim conforms to NACE MR0175

MODEL: EEW		UNIT: INCH								
Size	Pressure	FIGURE NO.		L	H	NPT	d	W	Weight [Lbs]	
		NON-NACE	NACE							
2" X 1-1/2"	750 PSI	EEW071-1-TD-G-L	EEW071-1-TE-G-L	5.4	4.8	11.5 NPT	1.5	8.5	9.9	
3" X 2"	750 PSI	EEW071-1-TD-G-L	EEW071-1-TE-G-L	7.3	5.6	8 NPT	2.0	10.0	19.2	
4" X 3"	750 PSI	EEW071-1-TD-G-L	EEW071-1-TE-G-L	8.8	7.6	8 NPT	3.0	15.0	40.8	

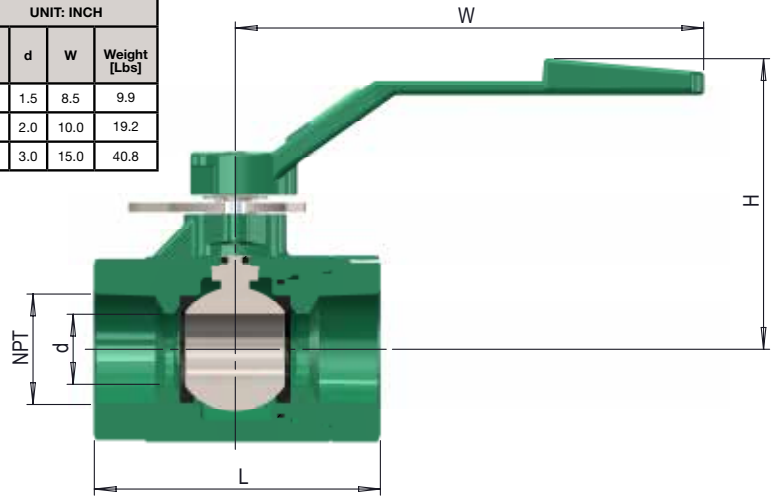

FORGED STEEL OIL PATCH BALL VALVE - THREADED

Model EW, EEW Forged Steel

SIZE RANGE : 1-1/2" - 2"
 PRESSURE : 3000 / 5000 PSI WOG
 TRIM : 316SS / 420SS [OPTION]
 OPERATOR : LEVER
 END CONNECTION : THREADED-NPT

- Full Port (1-1/2") & Reduce Port (2")
- Two-Piece Construction
- Fire Safe Design
- Excellent Stem Journal design with two O-rings
- Anti-Blow out Stem
- Standard locking Device configuration
- Stem lube fitting
- Double-D stem design
- Conforms to NACE MR-01-75 Standard
- Testing Standard: API 598
- Thread conform to: ASME B1.20.1 (NPT) API 5B (LP)



ITEM	PART NAME	MATERIAL
1	Body	ASTM A105
2	Seat	DELRIN [3000 PSI] PEEK [5000 PSI]
3	Ball	316 SS [NACE] / 420 SS [NON-NACE]
4	Body O-Ring	HNBR
5	End Cap	ASTM A105
6	Stem	316 SS [NACE] / 420 SS [NON-NACE]
7	Thrust Bearing	PTFE
8	Stem O-Ring	HNBR
9	Thrust Bearing	PTFE
10	Stop Plate	Carbon Steel
11	Retainer Ring	Carbon Spring Steel
12	Handle	Ductile Iron
13	Grease Fitting	Copper
14	Handle Bolt	Carbon Steel
15	Stopper	Carbon Steel
16*	Name Plate	Aluminium

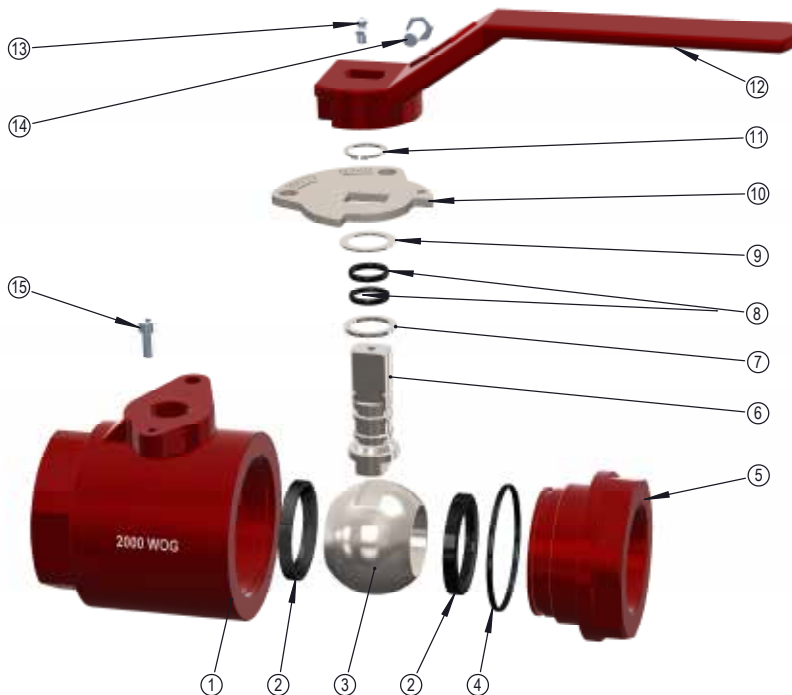

* Not shown on this view
 Note: All valves incorporating 316SS Trim conforms to NACE MR0175

MODEL: EW		UNIT: INCH							
Size	Pressure	FIGURE NO.		L	H	NPT	d	W	Weight [Lbs]
		NON-NACE	NACE						
1-1/2" X 1-1/2"	3000 PSI	EW301-1-AB-J-L	EW301-1-AC-J-L	5.5	5.3	11.5 NPT	1.5	8.7	14.3
1-1/2" X 1-1/2"	5000 PSI	EW501-1-AB-V-L	EW501-1-AC-V-L	5.5	5.3	11.5 NPT	1.5	8.7	14.3
MODEL: EEW		UNIT: INCH							
Size	Pressure	FIGURE NO.		L	H	NPT	d	W	Weight [Lbs]
		NON-NACE	NACE						
2" X 1-1/2"	3000 PSI	EEW301-1-AB-J-L	EEW301-1-AC-J-L	5.5	5.3	11.5 NPT	1.5	8.7	14.3
2" X 1-1/2"	5000 PSI	EEW501-1-AB-V-L	EEW501-1-AC-V-L	5.5	5.3	11.5 NPT	1.5	8.7	14.3

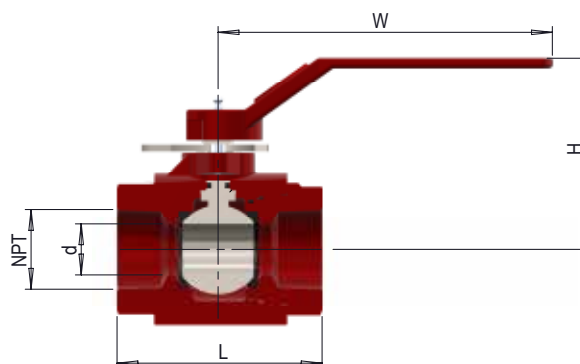

FORGED STEEL OIL PATCH BALL VALVE - BOLTED

Model FW, FFW Forged Steel

SIZE RANGE : 1-1/2" - 2"
 PRESSURE : 3000 / 5000 PSI WOG
 TRIM : 316SS / 420SS [OPTION]
 OPERATOR : LEVER
 END CONNECTION : THREADED-NPT

- Full Port (1-1/2") & Reduce Port (2")
- Two-Piece Bolted Body Construction
- Fire Safe Design
- Excellent Stem Journal design with two O-rings
- Anti-Blow out Stem
- Standard locking Device configuration
- Stem lube fitting
- Double-D stem design
- Conforms to NACE MR-01-75 Standard
- Testing Standard: API 598
- Thread conform to: ASME B1.20.1 (NPT) API 5B (LP)



ITEM	PART NAME	MATERIAL
1	Body	ASTM A105
2	Seat	DELTRIN [3000 PSI] PEEK [5000 PSI]
3	Ball	316 SS [NACE] / 420 SS [NON-NACE]
4	Body O-Ring	HNBR
5	End Cap	ASTM A105
6	Body Bolt	Carbon Steel
7	Stem	316 SS [NACE] / 420 SS [NON-NACE]
8	Thrust Bearing	PTFE
9	Stem O-Ring	HNBR
10	Stop Plate	Carbon Steel
11	Retainer Ring	Carbon Spring Steel
12	Handle	Ductile Iron
13	Handle Bolt	Carbon Steel
14	Grease Fitting	Copper
15	Stopper	Carbon Steel
16*	Name Plate	Aluminium

* Not shown on this view
 Note: All valves incorporating 316SS
 Trim conforms to NACE MR0175

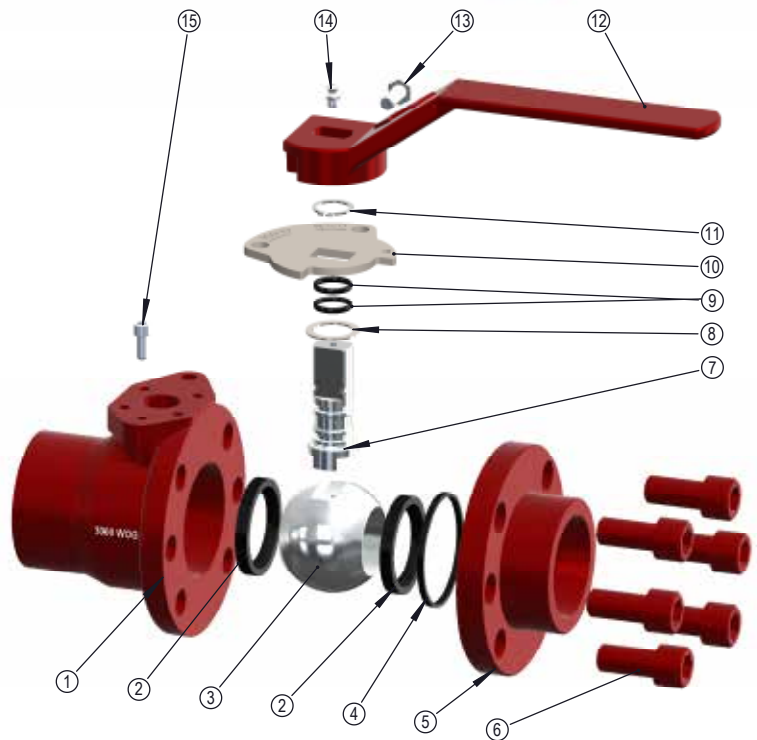

MODEL: EW		FIGURE NO.		L	H	NPT	d	W	Weight [Lbs]
Size	Pressure	NON-NACE	NACE						
1-1/2" X 1-1/2"	3000 PSI	FW301-1-AB-J-L	FW301-1-AC-J-L	5.5	8.1	11.5 NPT	1.5	8.7	18.1
1-1/2" X 1-1/2"	5000 PSI	FW501-1-AB-V-L	FW501-1-AC-V-L	5.5	8.1	11.5 NPT	1.5	8.7	18.1

MODEL: EEW		FIGURE NO.		L	H	NPT	d	W	Weight [Lbs]
Size	Pressure	NON-NACE	NACE						
2" X 1-1/2"	3000 PSI	FFW301-1-AB-J-L	FFW301-1-AC-J-L	5.5	8.1	11.5 NPT	1.5	8.7	18.1
2" X 1-1/2"	5000 PSI	FFW501-1-AB-V-L	FFW501-1-AC-V-L	5.5	8.1	11.5 NPT	1.5	8.7	18.1

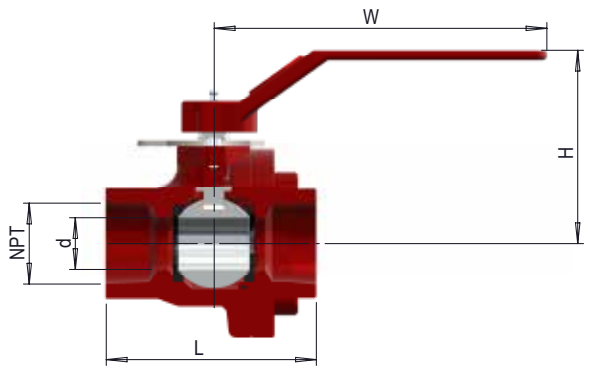

PRESSURE / TEMPERATURE CHART

The following chart indicates the pressure and temperature ratings for commonly used seat material in Oil Patch Floating Ball Valves.

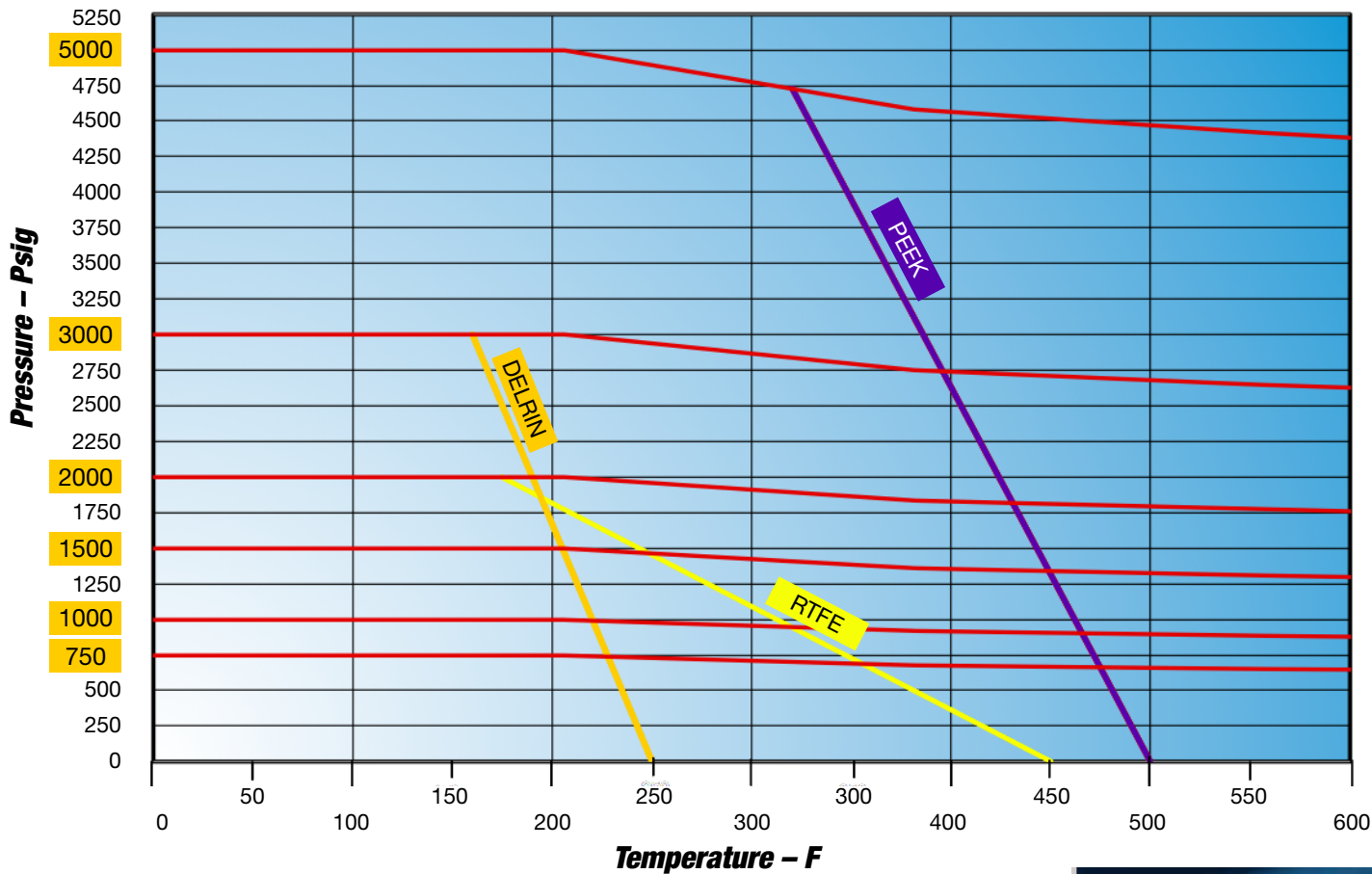



**WORLDWIDE
HEADQUARTERS**

GWC Italia S.p.A.

Via A. Grandi, 5
20056 Trezzo Sull'Adda
Milano, Italy

Phone: +39 02 86882941

Fax: +39 02 86882942

USA HEADQUARTERS

GWC Italia

8502 Crippen Street
Bakersfield, CA 93311

Phone: +1 661 834 1775

Fax: +1 661 834 2072

www.gwcitalia.com