

OIL SUPPLY SYSTEMS AND FIRE SAFE® OIL SUPPLY SYSTEMS

KENCO OIL SUPPLY TANKS AND STANDS

The KENCO Oil Supply Tank & Stand System is designed to supply lube oil to the crankcase of a compressor or engine in an isolated location where daily supervision and maintenance are an impossibility. KENCO Oil Supply Tank & Stand Systems used in conjunction with our Oil Level Controllers with low level switches can provide 24 hour protection from lubrication failure. Oil Supply Systems are available in 5, 16, 30 and 55 Gallon capacities.



55 Gallon

55 Gallon Oil Supply Tank mounted on a 36 inch stand. Featured with the optional 4400 Close-Mount Level Gauge



30 Gallon

30 Gallon Oil Supply Tank mounted on a 36 inch stand. Featured with the optional Galvanized finish and Condensate Drain Valve.



16 Gallon

16 Gallon Oil Supply Tank mounted on a 36 inch stand. Featured with the optional Fire Safe Valve and sight tube Isolation Valve.



5 Gallon

5 Gallon Oil Supply Tank mounted on a 36 inch stand. Featured with the standard, sight tube, drain valve and finish.

STANDARD TANK AND STAND MATERIALS OF CONSTRUCTION

*Tank Material—Carbon Steel
Tank Stand—Carbon Steel

Sight Tube—Polycarbonate
Sight Tube Connections—Brass

Drain Valve—Brass
Tank Vent—Carbon Steel

Seal Materials—Acetal, Buna & Teflon®

*Other tank materials available upon request.

NEW AND IMPROVED FEATURES

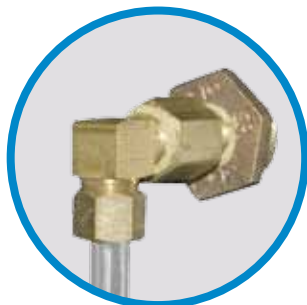

Sight Tube Connection

Sight tube connection threads directly into the face of the tank for simplified installation and maintenance.



Tank Vent (Breather)

Air vent allows tank to breathe while preventing dirt and other matter from contaminating the tank contents.

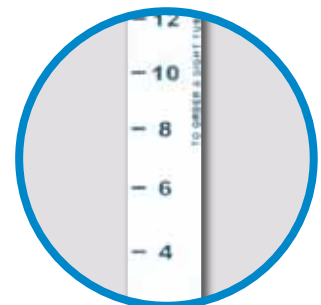

Volume Scale

Tank Volume Scale provides a visual means of monitoring crankcase oil consumption based on the volumetric capacity of the tank.

KENCO OIL SUPPLY TANK AND STAND OPTIONAL ACCESSORIES

ISOLATION VALVE

A Sight Tube Isolation Valve provides a means of isolating the sight tube from the contents of the tank. The Isolation Valve is ideal when performing routine maintenance or replacement of the sight tube.



4400 CLOSE-MOUNT LEVEL GAUGE:

The KENCO 4400 Close-Mount Level Gauge can be installed in place of the standard polycarbonate sight tube. The 4400 has a nickel plated brass frame that protects the sight tube on three sides from mechanical impact. The gauge features a redline glass sight tube which enhances the visibility of the sight tube contents.

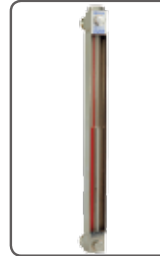

CONDENSATE DRAIN

A Condensate Drain is a unique outlet fitting which forms a sediment trap and is optional on K16, K30 and K55 gallon capacity Oil Supply Tanks. It is fitted with a side mounted drain cock for draining water and sediment without the loss of oil.

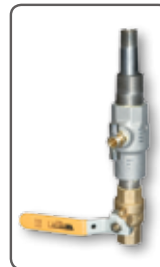

FIRE SAFE VALVE / FIRE SAFE VALVE WITH CONDENSATE DRAIN

A Fire Safe Oil Supply Tank has a thermally actuated outlet valve which closes in the event of fire near the oil supply tank. This prevents oil from escaping the tank and fueling the fire. The Valve closes off both the tank outlet and the sight tube. The melting point of the fuseable link is 160–190° F. The Fire Safe Valve is also available with a side mounted Condensate Drain plug.

* Other Temperature Ratings Available Upon Request. Consult Factory For Options.



GALVANIZED TANKS & STANDS

A Galvanized Oil Supply Tank or Stand has been coated with a corrosion inhibiting solution which serves to protect the tank against natural elements in environments that have a tendency to speed up the corrosion of metal products.



RUST PREVENTATIVE COATING

A Rust Preventative anti-corrosion coating is applied to the inside of the tank to provide an extra level of protection against the effects of corrosion resulting from environmental exposure.



HOSE KITS

Are available to simplify installation when connecting KENCO Oil Supply Tanks to KENCO Oil Level Controllers. Hose Kits consist of (1) 3/4" ID by 72" long general service hose, (2) 1/2" MNPT hose connectors, (2) 3/4" MNPT hose connectors and (4) band clamps.

REQUESTED BY: _____ COMPANY: _____

ADDRESS: _____ CITY: _____ STATE: _____ ZIP: _____

PHONE: _____ FAX: _____ EMAIL: _____

ORDERING SYSTEM 5 Gallon Capacity

Tank Size
5G=5 Gallon

***Tank Stand Height**
No Tank Stand (Leave Blank)
36=36" Stand

Tank Configuration
1/2" Drain Valve (Leave Blank)

Tank Sight Tube
Standard Sight Tube (Leave Blank)
IV=Standard Sight Tube w/
Isolation Valve
44=4400 Level Gauge

Tank and Stand Finish
Blue Painted Exterior (Leave Blank)
RP=Blue Painted Exterior w/
Internal Rust Preventative
Coating (N/A on Stands)

Tank Hose Kit
No Hose Kit (Leave Blank)
K=Hose Kit

Tank Sight Tube Repair Kit
No Sight Tube Repair Kit (Leave Blank)
RK=Sight Tube Repair Kit

• Example Order Number: 5G-36-IV

ORDERING SYSTEM K16, K30 and K55 Gallon Capacity Oil Supply Tanks

Tank Size
K16G=16k Gallon
K30G=30 Gallon
K55G=55 Gallon

***Tank Stand Height**
No Tank Stand (Leave Blank)
36=36" Tank Stand w/Mounting Strap(s)
56=56" Tank Stand w/Mounting Strap(s)
72=72" Tank Stand w/Mounting Strap(s)

Tank Configuration
1/2" Drain Valve (Leave Blank)
CD=1/2" Drain Valve w/
Condensate Drain
FS=1/2" Drain Valve w/Fire
Safe Valve
FS-CD= 1/2" Drain Valve w/Fire
Safe Valve and Condensate Drain

Tank Sight Tube
Standard Sight Tube (Leave Blank)
IV=Standard Sight Tube w/
Isolation Valve
44=4400 Level Gauge

Tank and Stand Finish
Black Painted Exterior
(Leave Blank)
RP=Black Painted Exterior
w/ Internal Rust Pre-
ventative Coating (N/A
on Stands)
GALV=Galvanized

Tank Hose Kit
No Hose Kit (Leave Blank)
K=Hose Kit

Tank Sight Tube Repair Kit
No Sight Tube Repair Kit (Leave Blank)
RK=Sight Tube Repair Kit

• Example Order Number: 55G-56-FS-CD-44-RP-K

ORDERING SYSTEM K16, K30 and K55 Gallon Capacity Tank Stands

***Tank Stand Height**
36S=36" Stand w/ Mounting Strap(s)
56S=56" Stand w/ Mounting Strap(s)
72S=72" Stand w/ Mounting Strap(s)
Other sizes available upon request

Tank Size
K16=16 Gallon
K30=30 Gallon
K55=55 Gallon

ORDERING SYSTEM 5 Gallon Capacity Tank Stands

***Tank Stand Height**
36S=36" Stand

Tank Size
5=5 Gallon

• Example Order Number: 36S-30

* Other Tank Stand sizes available upon request. Please consult factory for options.

KENCO OIL SUPPLY TANKS AND STAND OUTLINE DIMENSIONS

5 GALLON TANK AND STAND

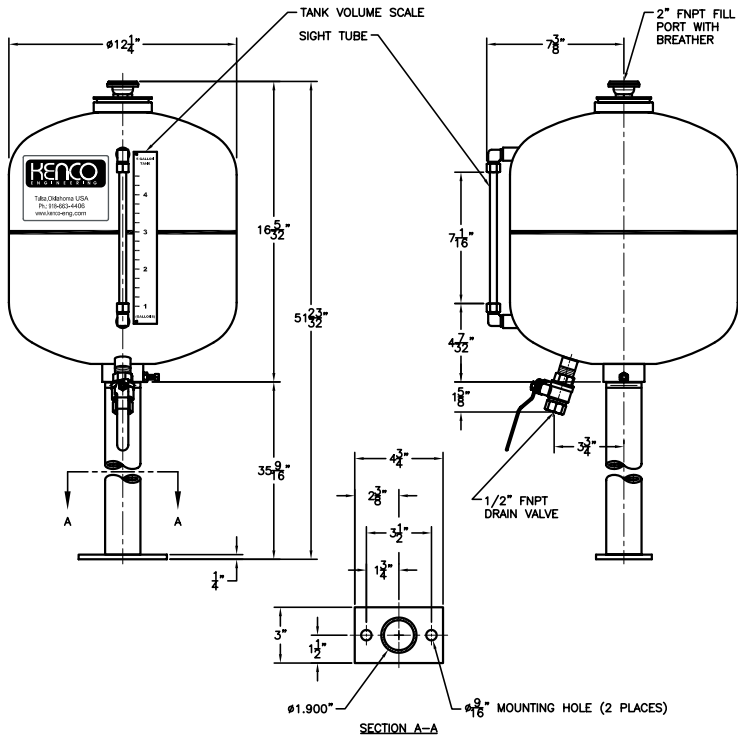

16 GALLON TANK AND STAND

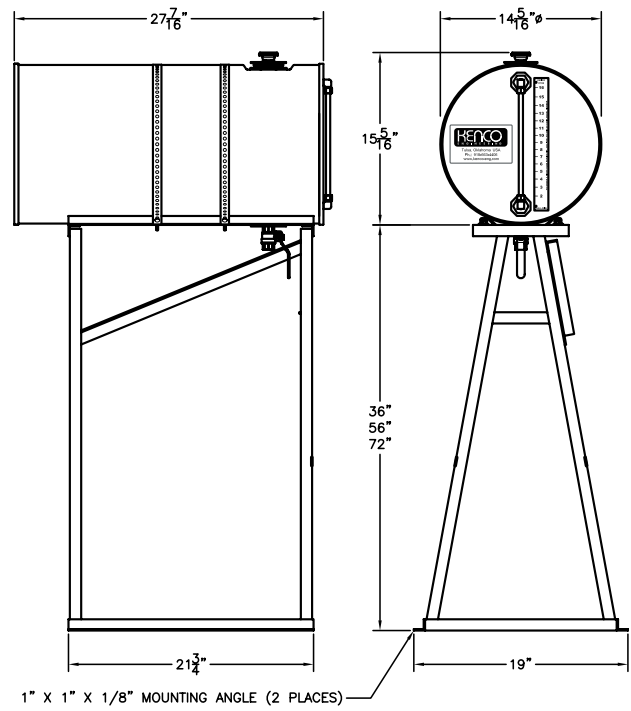

30 GALLON TANK AND STAND

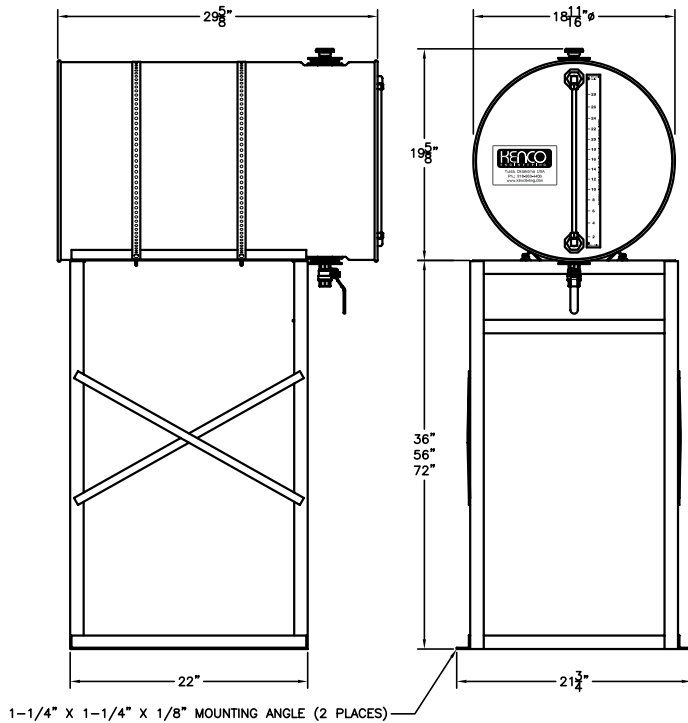

55 GALLON TANK AND STAND

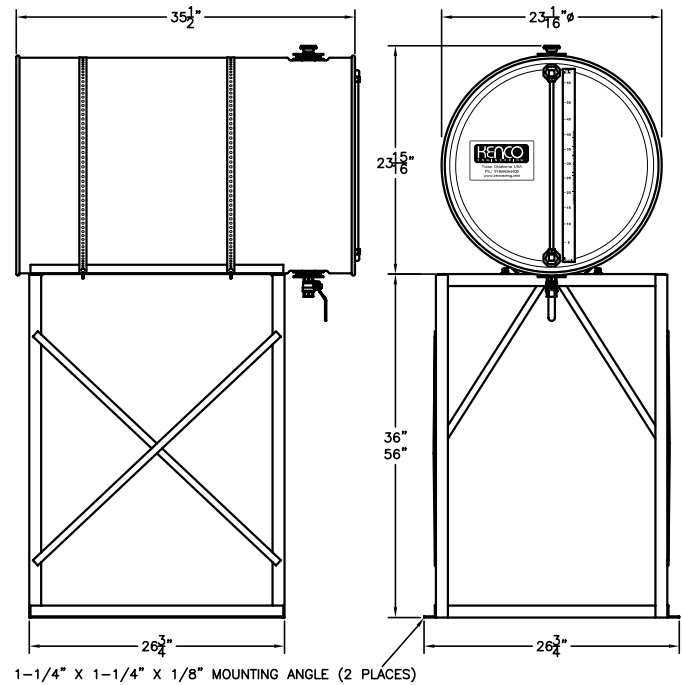

Represented by:

Kenco Sales Offices:

Headquarters

10001 E. 54th St.
Tulsa, OK 74146
phone 918.663.4406
fax 918.663.4480
www.kenco-eng.com
email: info@kenco-eng.com

Baton Rouge Office

11616 Industriplex, Suite 7
Baton Rouge, LA 70809
phone 225.755.1912
fax 225.755.1913
www.kenco-eng.com
email: kenco-la@kenco-eng.com

1-1-11

