



GALLI & CASSINA

Plus Valves

SINCE 1919



LUBRICATED



PLUG VALVES

PRESSURE

BALANCED

TYPE





Galli&Cassina Profile

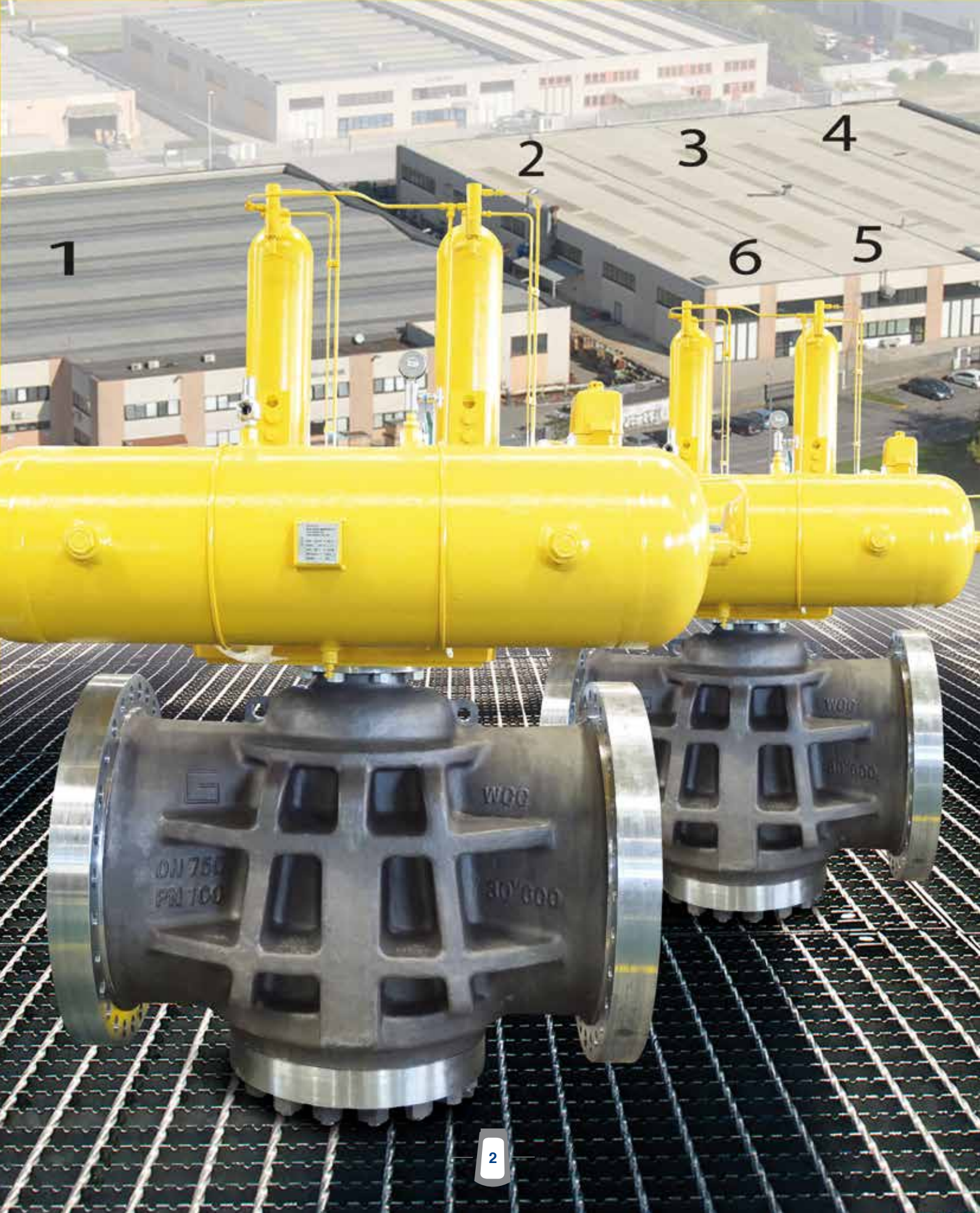

1

2

3

4

6

5



Galli&Cassina Profile



Galli&Cassina is a prominent Italian Company, leader in Design and manufacturing a complete range of Lubricated Plug valves.

The company is located in Solaro near to Milan (Italy)

Galli&Cassina was founded in 1919, and it is one of the oldest Italian companies which today is still in the valve business; in the beginnings G&C business activity was concentrated in the production of valves to serve the domestic growing market.

After the first ten years the company gradually turned its production towards the newly born Chemical Industry.

G&C was the first in Italy to produce valves in stainless steel and other special material in light with the demand

of the most important chemical companies.

It was not possible to expand further the Milan factory which was built in 1930 and enlarged after the second world war, for this reason in 1991 **Galli&Cassina** has moved to a new location in Solaro (Milan) with modern building and facilities.

After 30 years of experience in chemical valves, **Galli&Cassina** started the production of Plug Valves to serve the Oil & Gas worldwide market becoming one of the most significant supplier for all



with extensive offices and workshop covering 12.000 sq.mt. area including 5000 sq.mt. of covered space.



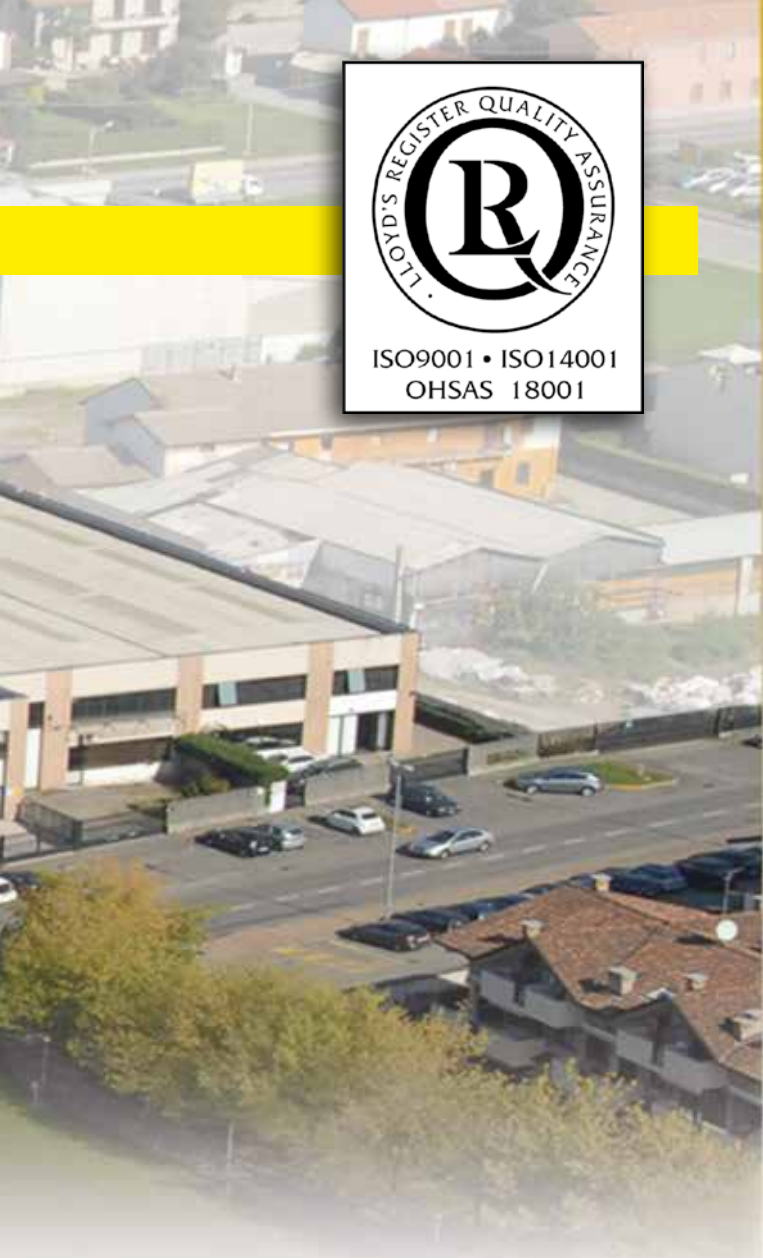

1. WORKSHOP & OFFICES.



2. WELDING.



3. MATERIAL RECEIVING.



4. TESTING AND INSPECTION.



5. PACKING AND SHIPPING.



6. WAREHOUSE.

International Oil & Gas companies across the world.

Its sales activity covers most of the continents with a leading and growing presence in Europe, Middle East, North & South America and Far East resulting in a sales and service network with subsidiaries, branch offices and distributors, achieving the reputation of high quality and reliable product.

Galli&Cassina pays a particular attention to company development in every area, to be in line with the continuous market evolution.

The proved technical, production, and financial

capabilities combined with experience of human resources are the result of Galli&Cassina reputation all over in the world.

Galli&Cassina's Quality Assurance System & HSE according to ISO 9001-2008, ISO 14001 & ISO 18001 have been assessed, approved and certified by Lloyd's Register, while the API 6D and 6A monogram have been certified by API

(American Petroleum Institute) - Washington U.S.A. Nowadays Galli&Cassina is

proud to celebrate its 95 years presence in the world valves market.



Plus Valves.

The Production Range



**Two Way
Standard Type**

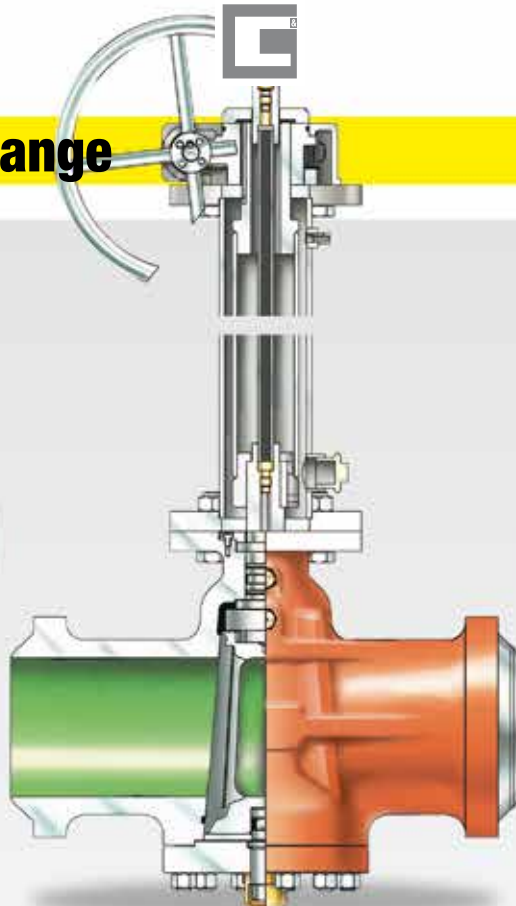

**Two Way Pressure Balanced Type
with Stem Extension**

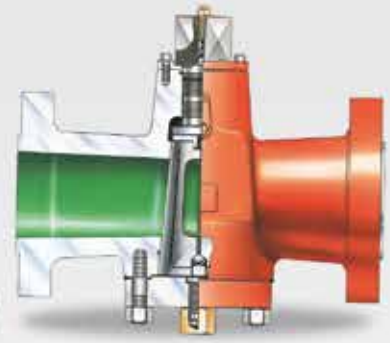

**Two Way Pressure
Balanced Type**

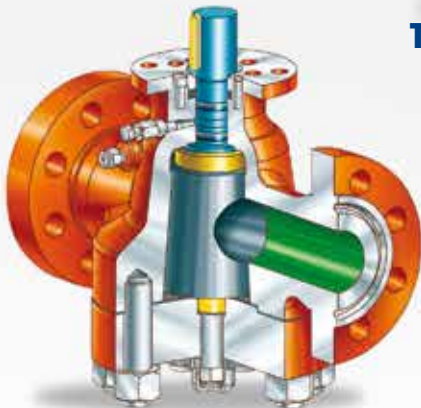

**Two Way LGC
Pressure Balanced
Full Bore Type**

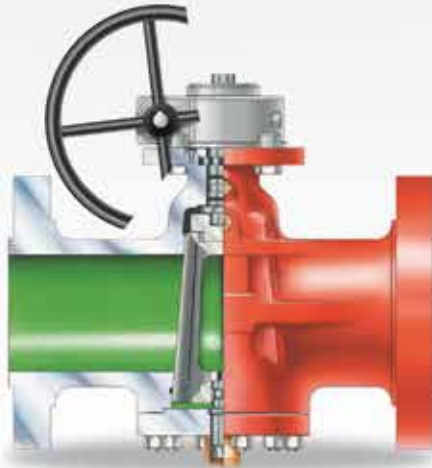

**Two Way Pressure
Balance Type Gear Operated**



**Two Way with
PTFE Sleeve 3S Series**

Actuators Availability

Electric



Pneumatic



Electro Hydraulic



Gas Overoil





Machining and Manufacturing

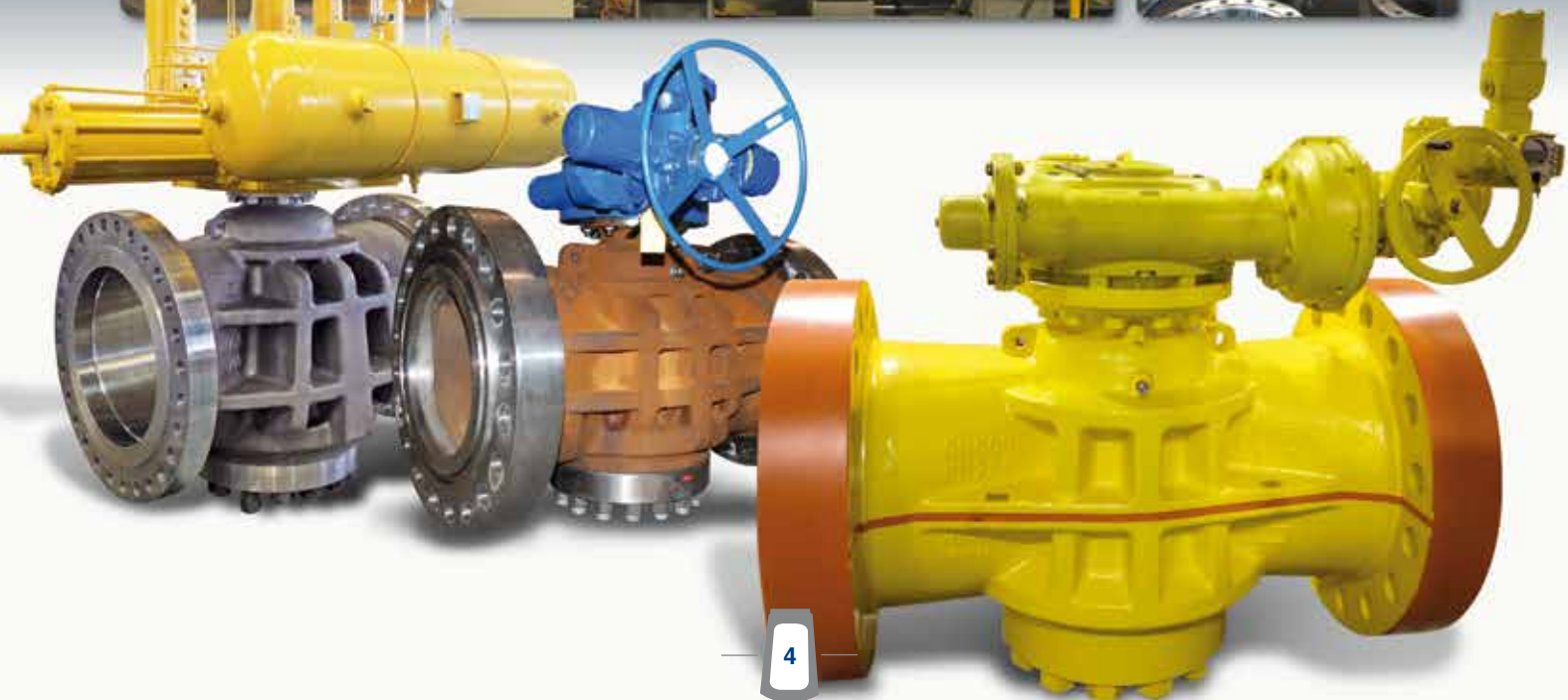



Index

Company Profile	2-3
Maching & Manufacturing Facilities	4
Index	5

Galli&Cassina Products

Material Selection Guide for GALLI&CASSINA Valves Standard Design Categories (Typical Construction Materials)	6
Applicable Standard-Specification	7
Standard Features	8
The Pressure Balance System	
Standard Features Patterns	
Standard Features	9
Plug PTFE Antifriction Treatment	
Special Features Coating & Overlay	10
Fire Safe Test	11
Available Tests	
Advanced Design	12-13
Valve Assembly	14
Valve with Wrench	15
Cross Section Drawing	
Product Identification System	16
ANSI Class 150 to 2500 (PN 20 to PN 420)	17
ANSI Class 150 (PN 20)	18-19
ANSI Class 300 (PN 50)	20-21
ANSI Class 600 (PN 100)	22-23
ANSI Class 900 (PN 150)	24
ANSI Class 1500 (PN 250)	25
ANSI Class 2500 (PN 420)	26

Engineering Data

Pressure Balanced Plug Valves API 6A 2000-3000-5000-10000	27
Hydraulic Pressure Test Duration Marking	28
Pressure Test Tables in Accordance with API598 & API 6D	29
Quality Assurance Programme	30
Quality Assurance System	31
Quality Assurance Development	
Customer Service	

Quality Assurance Programme

Lubricants	34
Climax Hydraulic Gun N. 1699	34
Climax Lubricants	35
Routine Maintenance Instructions	36
Engineering Data	37
Conversion Tables	38-39
Temperature Conversion Table	40
Pressure/Temperature Rating according to ASME B16.34-2013	41
Chemical and Mechanical Requirements Forged/ bar Materials for Body, Plug, Cover and Stem Components	42-43
Chemical and Mechanical Requirements Cast Materials for Body, Plug and Cover Components	44-45
Chemical and Mechanical Requirements Bolting Materials (Body/Plug)	
Plug Valve Dimensions according to API Standard 6D/ISO 14313	46-47
Plug Valve Dimensions according to API Standard 6A/ ISO 10423	48
Qualification of other Size Valves - API 6FA	49
Qualification of other Pressure Rating Valves	
Plug Valve Application	50
The Production Range	51
Actuators Availability	
GALLI&CASSINA in the World	53

The data reported in this catalogue refer to the International Standards applicable at the time of its issue date.

Galli&Cassina reserves the right to modify its products without any obligation to notify, provide or install such modification on products previously or subsequently sold.

However Galli&Cassina will use the best afford to keep the customers informed of any changes made.

GALLI & CASSINA



Material Selection Guide for GALLI&CASSINA Valves

Trim materials are designed according to the service conditions.

- 1** Standard Carbon Steel Body and Plug. (ASTM-A216 WCB/WCC material) suitable for general services.
- 2** Carbon Steel Body and Plug (A352 LCB/LCC material) suitable for low temperature services.
- 3** Carbon Steel Body and Plug (ASTM A216WCB/WCC material) suitable for "SOUR SERVICE"(H₂S and CO₂) according to NACE-MR.01.75/Latest Edition.
- 4** Special Austenitic (6MO) and Ferritic-Austenitic Stainless Steel (Duplex and Superduplex) suitable for sea water and corrosive services.
- 5** Nickel-Chromium-Iron alloy (i.e. Alloy 20), Titanium & Titanium alloy, carbon steel with Inconel 625 cladding and stellite or Tungsten carbide hardfacing for abrasive/corrosive service.
- 6** Other materials upon request.

Standard Design Categories (Typical Construction Materials)

Trim Service	Class	Body/Cover	Plug	Stem and Oldham Coupler	Bolting
1 Standard service Natural gas Hydrocarbons	150 to 2500	ASTM A105 ASTM A216 WCB/WCC Max C 0.25%	ASTM A105 ASTM A216 WCB/WCC	ASTM A29 Gr. 4140	ASTM A193-B7M ASTM A194-2HM
2 Low temperature Natural gas Hydrocarbons	150 to 2500	ASTM A350-LF2 ASTM A352 LCB/LCC Max C 0.23%	ASTM A350-LF2 ASTM A352- LCB/LCC	ASTM A29 Gr. 4140	ASTM A320-L7 ASTM A194 Gr.7
3 Sour Service (H ₂ S and CO ₂) Hydrocarbon s	150 to 2500	ASTM A105 ASTM A216 WCB/WCC Max C.0.23% Max HRC22	ASTM A105 ASTM A216 WCB/WCC Max C.0.23% Max HRC22	ASTM A29 Gr. 4140 Max HRC22	ASTM A193-B7M ASTM A194-2HM MAX HRC22
4 Sea Water	150 to 2500	UNS S31254 ASTM A 351 CK3MCuN (6MO)	UNS S31254	UNS S31254	ASTM A453 Gr.660A
		UNS S31803 ASTM A 890 J92205 (Duplex 22% Cr)	UNS S31803	UNS S31803	ASTM A453 Gr.660A UNS S32760
		UNS S32750 ASTM A 890 J93404 (Super duplex 25% Cr)	UNS S32750	UNS S32750	UNS S32760
		UNS S32760 ASTM A 890 J93380 (Super duplex 25% Cr)	UNS S32760	UNS S32760	UNS S32760
5 Abrasive/Corrosive Slurry service	150 to 2500	ASTM B348 Gr 3 or 5 (Titanium)	ASTM B348 GR 3 or 5	UNS S31254 UNS S32760	ASTM A453 Gr.660A
		UNS N08020 ASTM A 351 CN7M (Alloy 20)	UNS N08020 ASTMA351CN7M	UNS S32750 UNS S32760	ASTM A453 Gr.660A UNS S32760
		ASTM A 105 ASTM A 216 WCB/WCC Hardfacing (Stellite/WC) and Cladding (Inconel 625)	Gr 4140	ASTM A 29 ASTM A194 2HM	ASTM A193 B7M



Applicable Standard-Specification

Lubricated Plug Valves are designed to use with most refining services according to API 599 or BS 5353 norms whichever is applicable.

API 6D norm aims to standardize the materials as well as instructions to manufacture valves suitable for energy transportation in the pipelines.

API 6A	Specification for wellhead and christmas tree equipment.	BS 1504	Specification for Steel Casting for Pressure Purposes.
API 6D	Specification for Pipeline Valves.	BS 2080	Face to Face - Centre to Face - End to End - Steell Valves.
API 6FA	Specification for Fire Test for Valves.	BS 5353	Specification for Steel Plug Valves.
API RP6F	Recommended - Practice for Fire Test for Valves.	BS 6755 part 1	Testing of Valves (Spec. for Production Pressure Testing Requirements).
API 598	Valve Inspection and Testing.	BS 6755 part 2	Testing of valves (Spec. for Fire Safe Testing Requirements).
API 599	Steel Plug Valves Flanged or Butt Welding Ends.	CSA Z 245. 15	Canadian Standard Association.
ASME/ANSI B 16.5	Pipe Flanges and Flanged Fittings.	MSS-SP6	Standard Finish for contact Face of Pipe Flanges.
ASME/ANSI B 16.10	Face-to-Face and End-to-End Dimensions of Valves.	MSS-SP25	Standard Marking System for Valves.
ASME/ANSI B 16.25	Buttwelding Ends.	MSS-SP44	Steel Pipe Line Flanges.
ASME/ANSI B 16.34	Valves-Flanged, threaded and Welding Ends.	MSS-SP53	Quality Standard for Steel Casting-Magnetic Particle Examination Method.
ASME/ANSI B 31.3	Chemical Plant and Petroleum Refinery Piping.	MSS-SP54	Quality Standard for Steel Casting-Radiographic Examination Method.
ASME/ANSI B 31.4	Liquid Trasportation System for Liquid Petroleum Gas.	MSS-SP55	Quality Standard for Steel Casting Visual Method.
ASME/ANSI B 31.8	Gas Transmission and Distribution Piping System.	MSS-SP61	Pressure Testing of Steel Valves.
ASME	Boiler and Pressure Vessel SECTION VIII - DIV.1 & 2	NACE Std. MR 01.75 Latest Edition	National Association of Corrosion Engineers.
ASME	Boiler and Pressure Vessel Section V.	ASTM	American Society for Testing and Materials.
ASNT-TC-1A	Reccomended Practice for Personnel Qualification and Certification in Non destructive Testing.		



Introduction

- Plug Valves are probably the oldest and most commonly used valves in modern pipelines.
- Plug Valves have been used more than 2000 years, ever since the time of ancient Rome.
- Lubricated Plug Valves use special lubricant to ease their operation over a wide range of operating pressure. The lubrication film (between plug and body) also provides a seal and only requires periodic lubricant injection.
- No spare parts.
- Bubble tightness is always guaranteed in critical service.
- Maintenance is reduced to a periodic lubricant injection.
- Complete overhauling of the valve, or line shut off "are not required" in case of seat leakage.

Standard Features: the Pressure Balance System

The operating system of Pressure Balanced Plug Valves (shown in Fig.A) consist in the pressure equalization between the port area and the top/bottom of the plug with two holes. The upper hole connects the plug port area with the top of the plug, while the lower maintains the pressure equalization between the port area and the bottom of the plug. The Pressure Balance System ensure line pressure acts on the plug to reduce the valve torque and avoid the possibility of plug seizure, even after a prolonged time in the open or closed position. The tapered shape of the plug guarantees that the force created by line pressure pushes the plug against the seat. As differential pressure increase so does the sealing capability of the Pressure Balanced

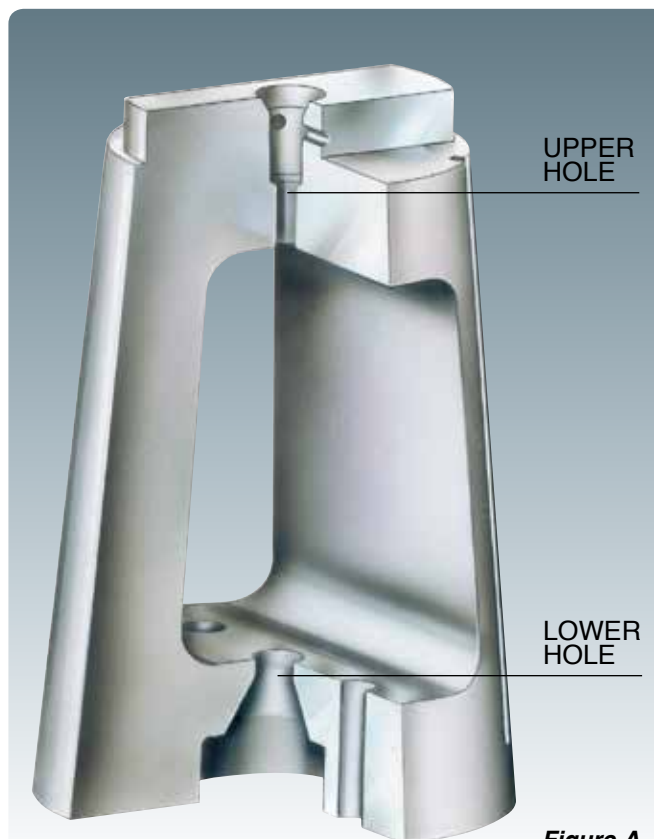

Figure A



Plug Valve. Thanks to pressure balance feature, and to the integral metal to metal design, Plug Valve can always be opened against the maximum delta p. No by-pass is necessary to preserve seat integrity. Periodic lubricant injection, and seat adjustment can be carried out when the Plug Valve is under full pressure. Only severe seat damage will cause a reduction of valve sealing.

Standard Features Patterns:

Galli & Cassina Plug Valves are available in four different patterns. The pattern indicates basic information about the

Short Pattern

Short Pattern Plug Valves have compact face to face dimensions (like a Gate Valve) and rectangular port areas of 40% to 60% of a Full Bore Plug Valve. This provides an economical valve for services where some reduction of flow rates can be tolerated. The Short Pattern is only in classes 150 and 300.

Venturi Pattern

Venturi Pattern Plug Valves also have a longer face to face but with a rectangular port areas of 40-50% of a Full Bore Plug Valve. These are typically used on services where flow rate is not critical. The long lead into and out of the port minimises pressure drop when the valve is fully opened.

valve in terms of end to end dimension (according to API 6D & BS 5353) & the size of the flow port through the valve.

Regular Pattern

Regular Pattern Plug Valves have longer face to face dimensions and rectangular port areas of 50-70% of a Full Bore Plug Valve. This configuration provides minimal loss of flow while economising on the overall valve dimensions from using rectangular port.

Full Bore

Full Bore Plug Valves have long face to face dimensions and a round port than is not smaller than minimum diameter specified in Annex A of ASME B16.34 or/and API 6D. This configuration provides unrestricted flow and allows the passage of pigs through the valve. It is also recomanded for highly abrasive conditions as it minimises pressure drop and erosion in the valve.



Standard Features: Plug PTFE Antifriction Treatment

Carbon Steel plugs are subjected to the following treatments:

- A) Case hardening.
 - B) Antifriction treatment.
- The case hardening has the purpose to increase

only the hardness of the plug surface which is subjected to wearing, keeping at the same time the mechanical properties of the base material unchanged.

Consequently the base material has more toughness and resistance against impacts. The Antifriction treatment is basically carried out on the plug to obtain

- the following advantages:
- Low friction between plug and body.
 - Low torque.
 - Wear resistance.
 - Resistance to seizure.

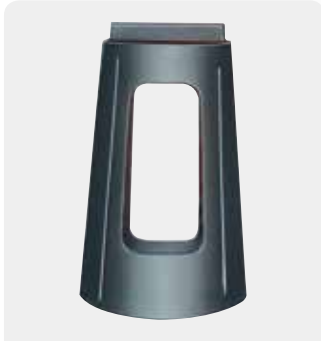

Plug with PTFE Antifriction treatment.



Plug without PTFE Antifriction treatment.



Plug with PTFE Antifriction treatment.



Plug without PTFE Antifriction treatment.

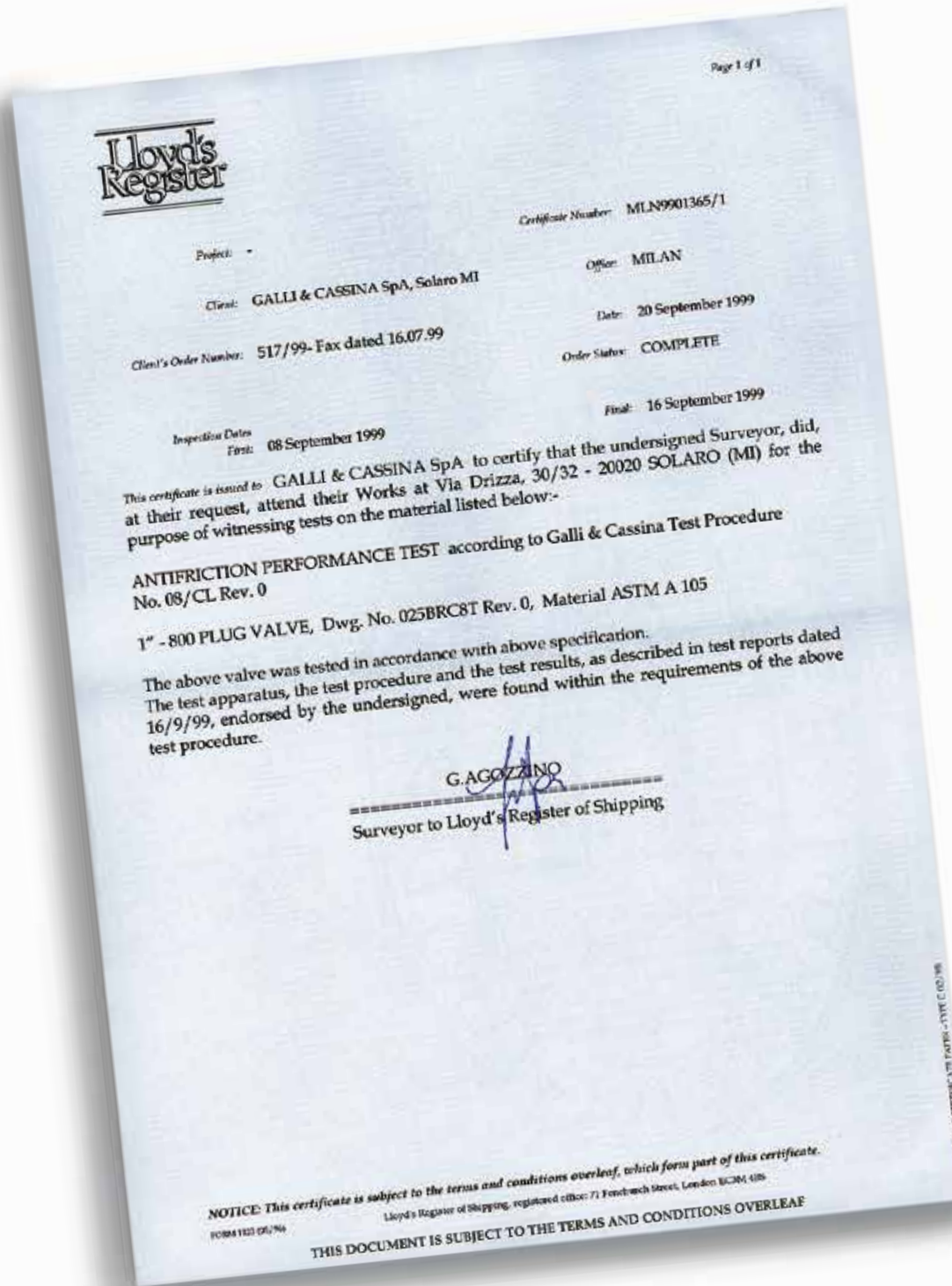

▲ The purpose of the above test is to prove that Galli&Cassina antifriction treatment made on plug surface, is guaranteed even after 30,000 cycles (open/closed position).



Special Features: Coating & Overlay

Hardfacing

The most common damages of valves are either due to abrasion by solids in the flow lines, or the exposure of main components to corrosion attack. Galli&Cassina's researching and development in cooperation with specialized companies and laboratories, have been the development of special hardfacing and corrosion resistant materials, which have achieved excellent results in Off-Shore application. Most of the main materials used are as follows:

Stellite-Duplex-6MO
Inconel 625-Nickel
Alloy 686 Ultimet Alloy (UNSR31233)
Tungsten Carbide.



Electrolles

Nickel Plating

The transport of wet hydrocarbon gases contaminated with hydrogen sulphide, carbon dioxide or other similar fluids containing appreciable level of sulphur, can create various corrosion problems to some component in plug valves.

These environments are not always recognized under service conditions,

therefore in order to obtain a high quality corrosion resistant, all the material for each component of the valves, are selected in accordance with the requirements of NACE-Std. MR-01-75 Latest Edition. Moreover the use of an electroless nickel plating on plug surface provides more corrosion protection to hydrogen sulphide crack-resistant base metal. Standard ENP is in

accordance with ASTM B733 Std with a minimum 0.003" (76 Microns) thickness, unless otherwise specified in the customer's specification.

Tungsten Carbide Coating

A series of metal carbide coatings (WC+Ni, Cr or WC+Co or WC+Co, Cr), usually known as Tungsten Carbide (TCC)

allows to achieve higher performance in terms of valve working life. These performances are specially highlighted in case of severe operating conditions. Moreover, higher hardness values (greater than 1100 HV / 70 HRC) compared to standard hardfacing Stellite 6, (37 - 40 HRC) provide a very good abrasion & wear resistance.

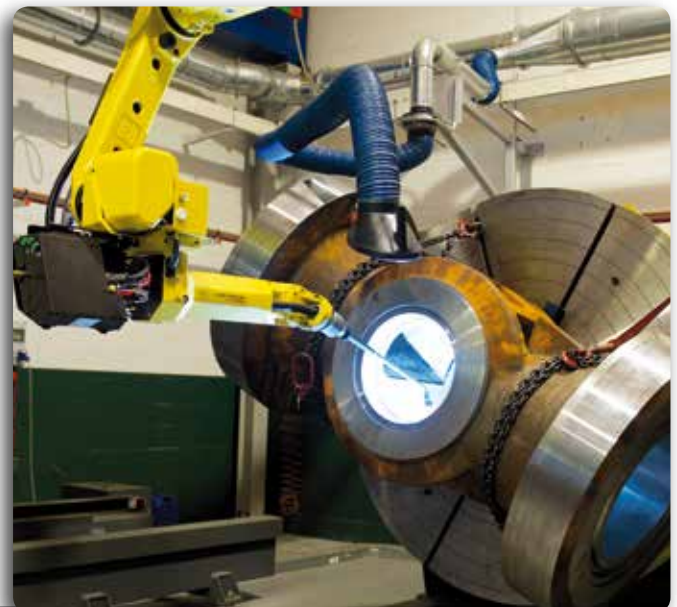



Fire Safe Test

All Galli&Cassina's Plug Valves have been tested against fire resistance, according to API - 6FA and BS 6755 - Part 2 standards and witnessed by international third party.



Metal to Metal Seat, diaphragm sealing as well as the stem sealing compound with graphite guarantees a high reliability performance of our Plug Valves while in exposure to Fire Test conditions.

Available Tests

Type of Test	Applicable Standards	Performance
X AND GAMMA RAYS	ANSI B16.34 - Annex-B ASME VIII - Div.1 - MSS - SP 54 ASTM E446 - E186 - E280	100% all butt welding ends and body.
DYE PENETRANT	ASME V - art.6 and 24 - ASTM E142 100% ANSI B16.34 - Annex-D MSS-SP-93	All butt welding ends
MAGNETIC - PARTICLES (Dry and wet)	ASME V - art.7 and 25 ANSI B16.34 - Annex C - MSS - SP 53	100% of all valves
ULTRASONIC	ASME V - art.4 and 23 ASME VIII - Div.1 - ASTM - A388	Upon customer request
VISUAL AND DIMENSIONAL	MSS - SP 55 ANSI B16.5 - B16.10 API 6D - (Table 4.2)	100% of rough and finished machined components and assembled valves
HARDNESS	NACE - MR.01.75 Latest Edition	100% of wetted components
HYDROSTATIC AND PNEUMATIC	API - 6D - API 598 BS 6755 - Part.1 - MSS - SP 61	100% of all valves
OPERATION TORQUE	API - 6D	Upon customer request
HIGH PRESSURE CLOSURE	API - 598 - Par. 4-5	Upon customer request
POSITIVE MATERIAL IDENTIFICATION	ASTM A751	100% of pressure containing components





Advanced Design

Three-dimensional CAD system and the Finite Element Modelling allow the optimization of every step of valve's design:

- FEM stress calculation of the pressure containing parts **(A)**
- Raw Casting design **(B)**
- Final Assembly Design Check **(C)**

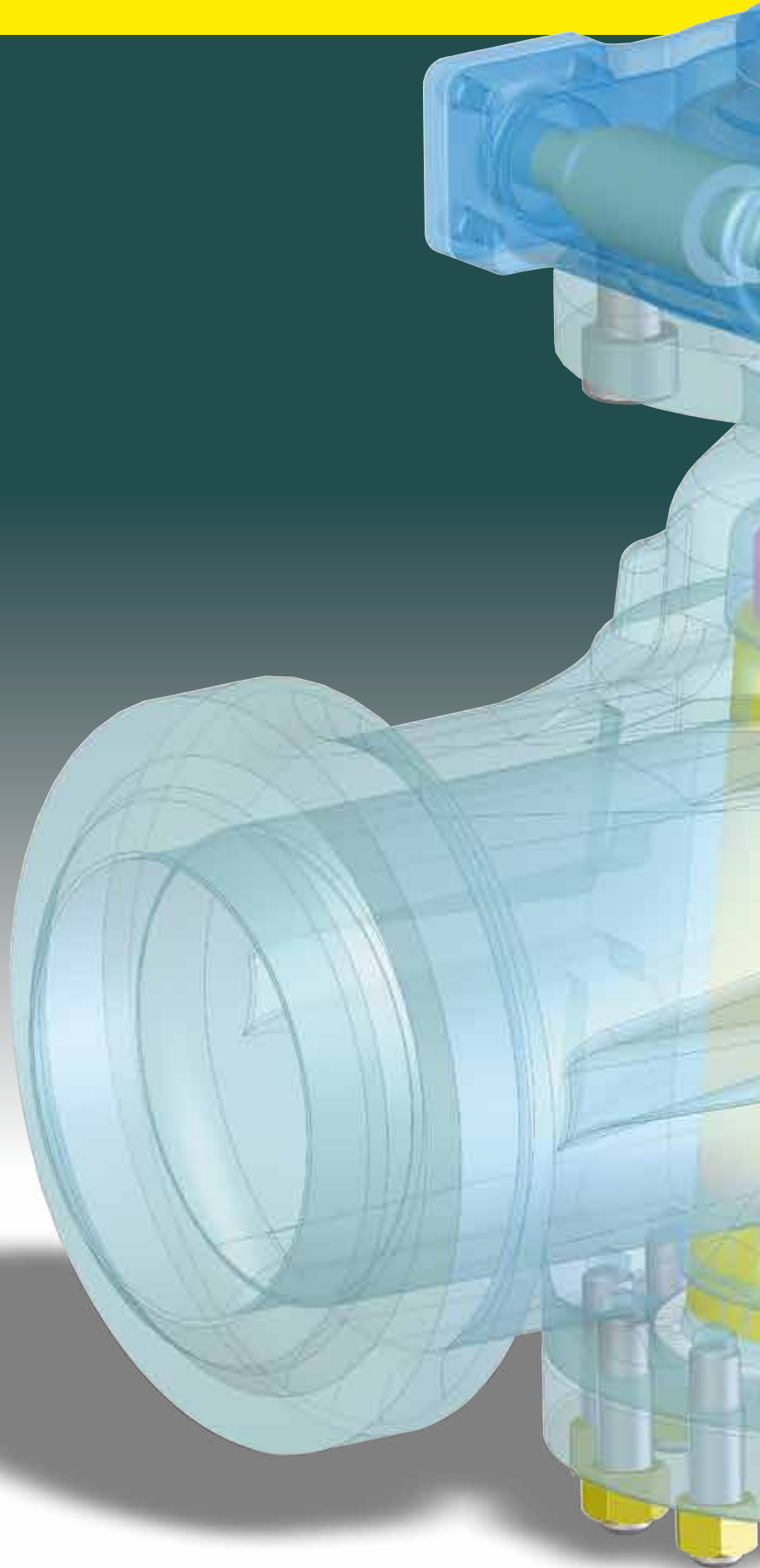
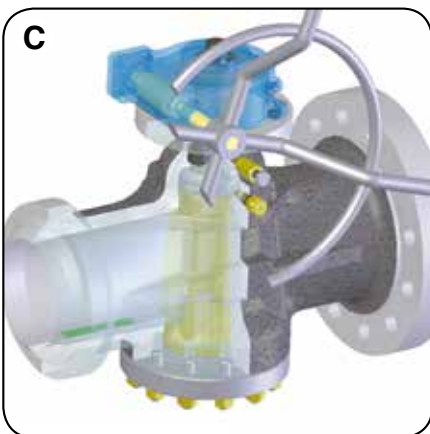
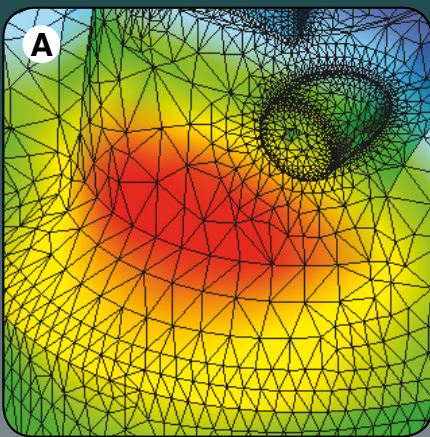

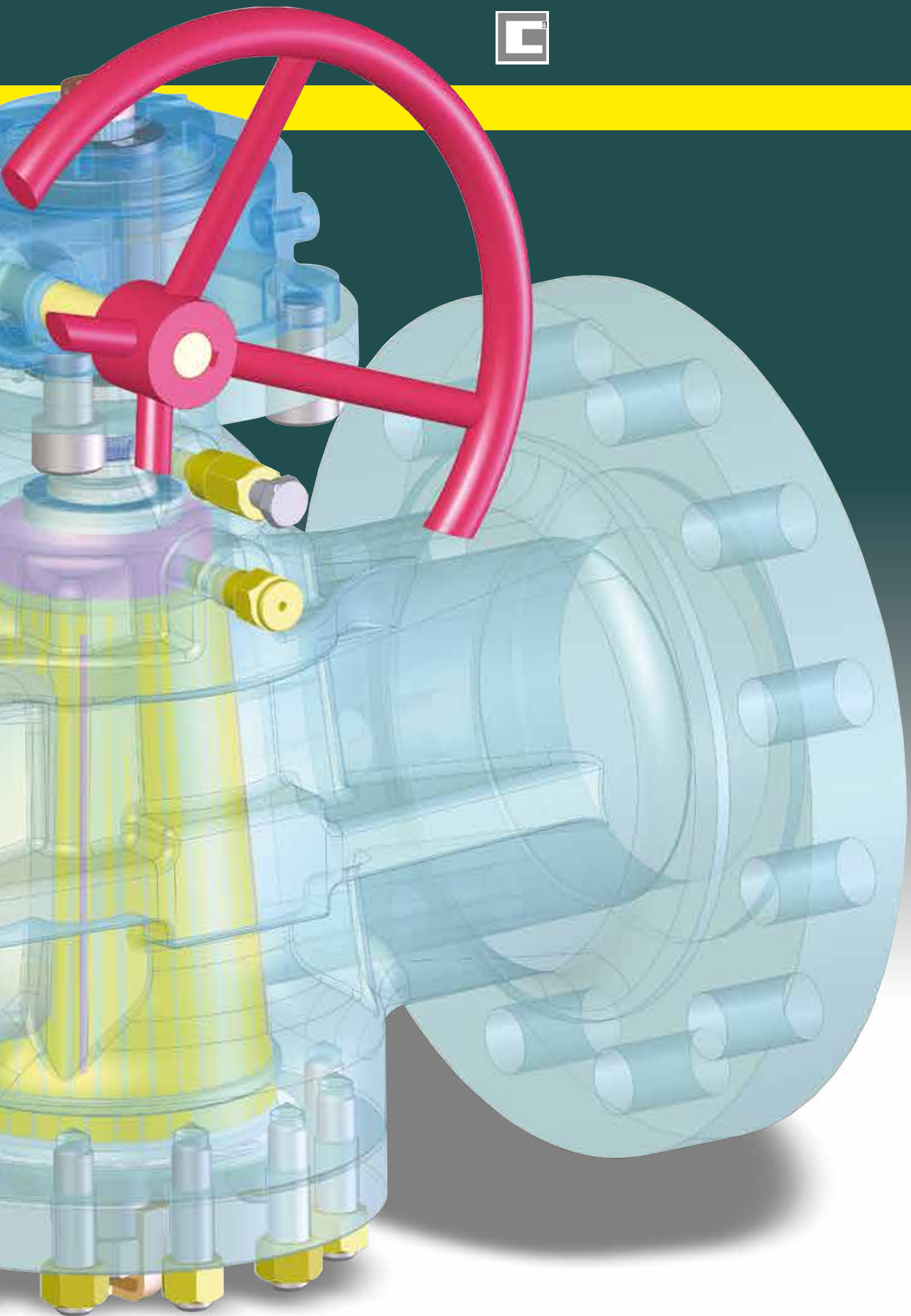



Valve Assembly

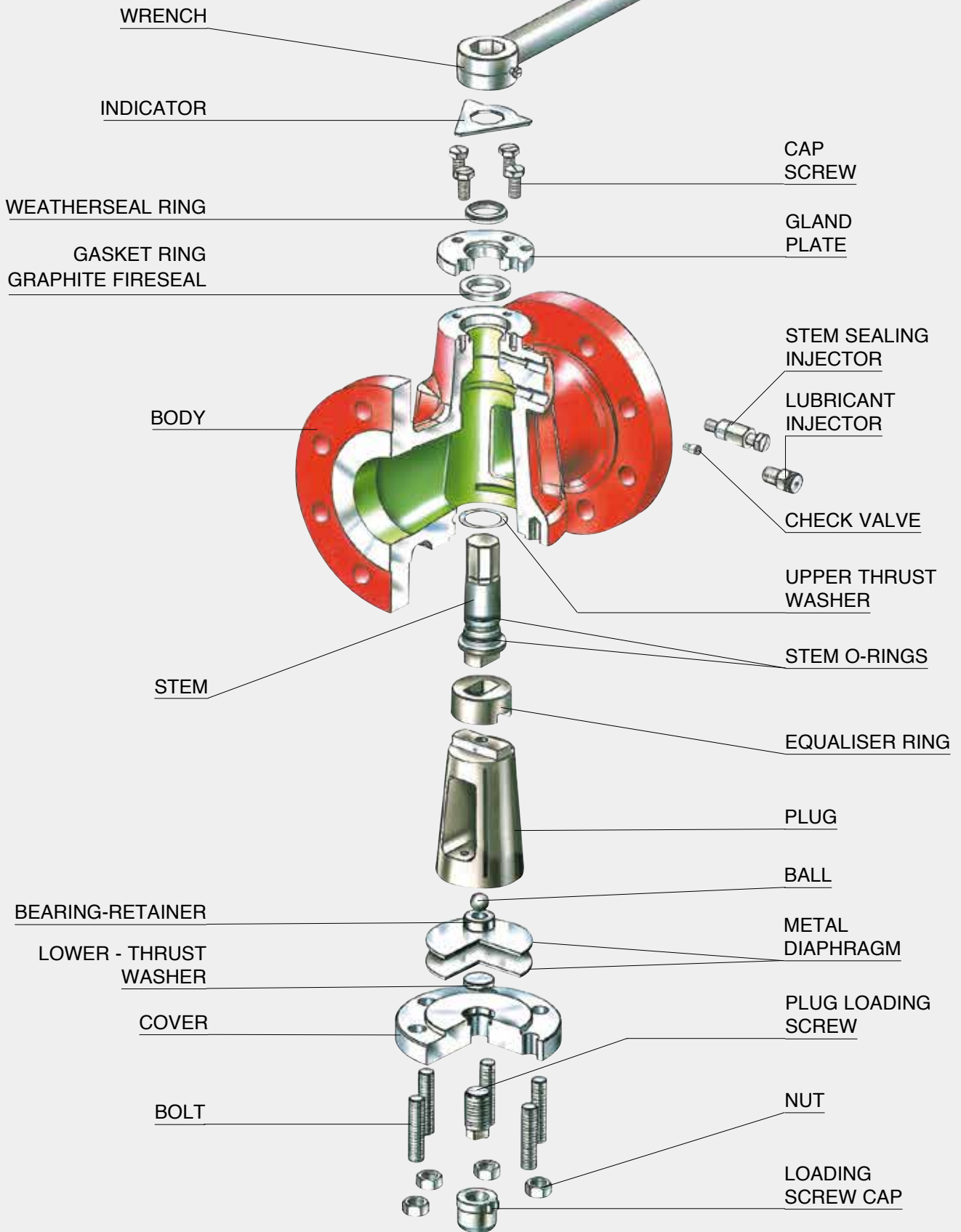



Valve with Wrench: Cross Section Drawing

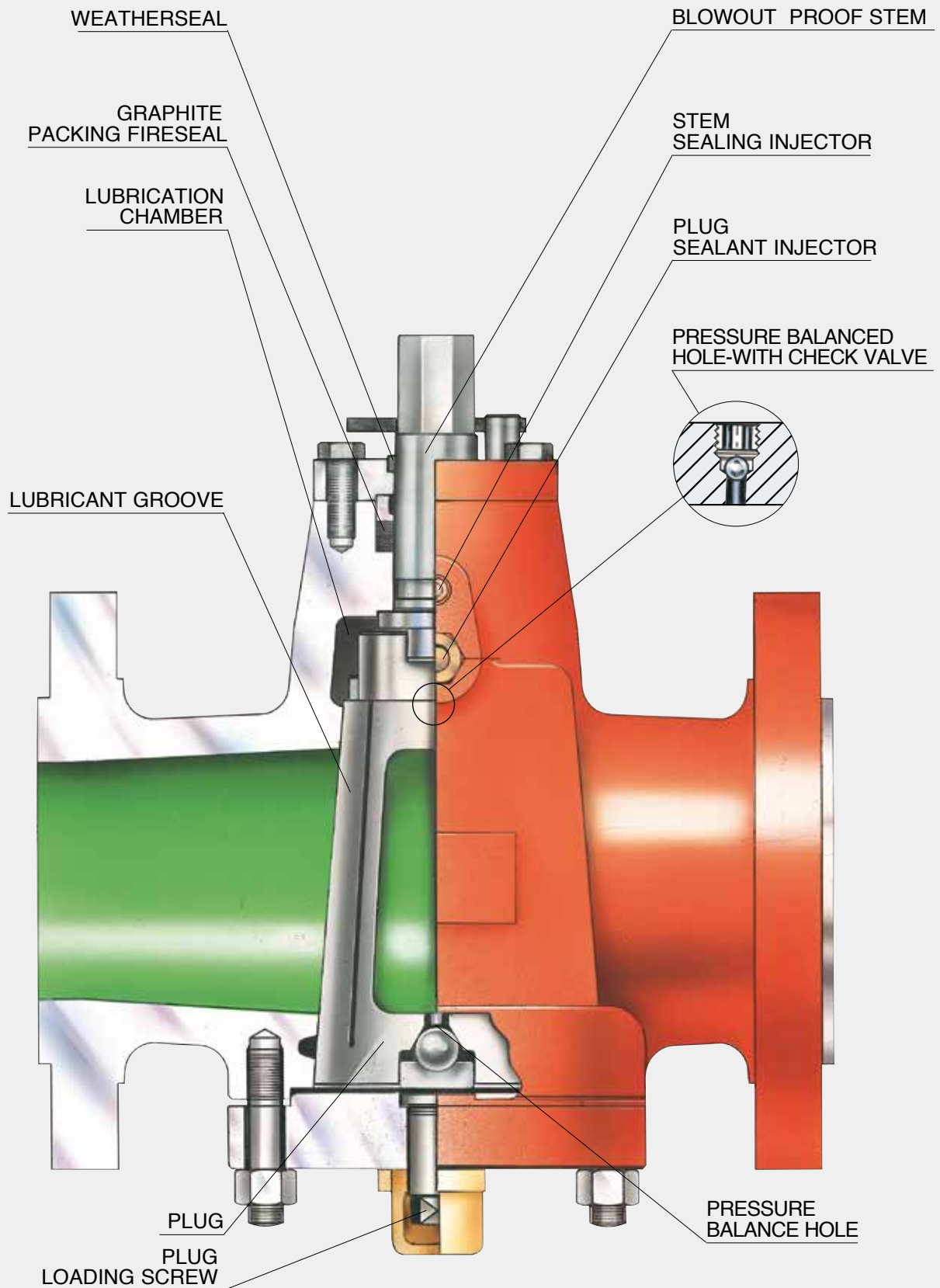

NOTES: Each valve with wrench operation, the plug open and closed position are assured by corresponding stop indicator fitted on bare stem. The open position of the valve has the stop indicator parallel to flow direction of the fluid.



Valve with Gear: Cross Section Drawing

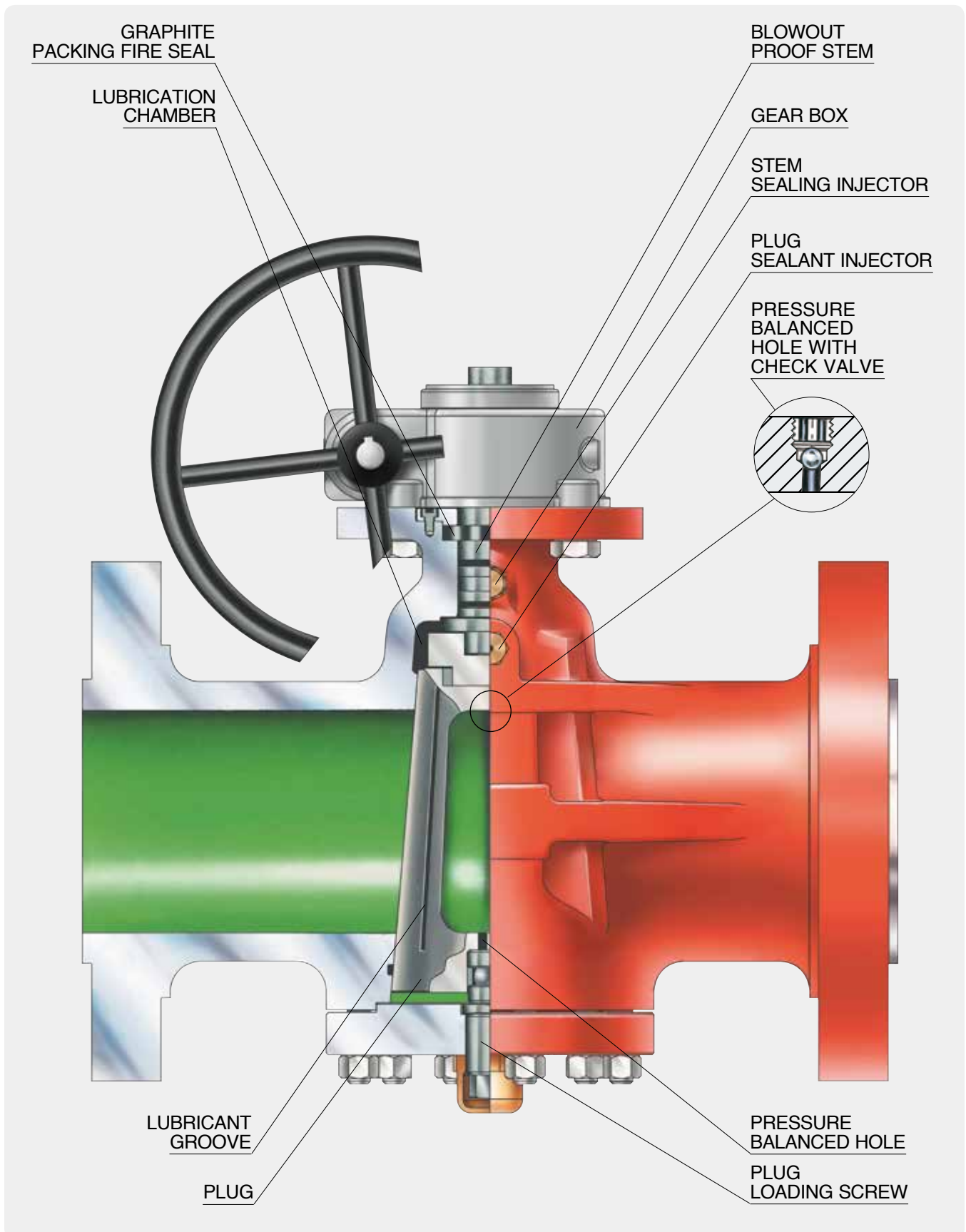

NOTES: Each valve with gear operation, the plug open and closed position are assured by corresponding stop indicator fitted on top of gear. The open position of the valve has the stop indicator parallel to flow direction of the fluid.



Valve with Stem Extension: Cross Section Drawing

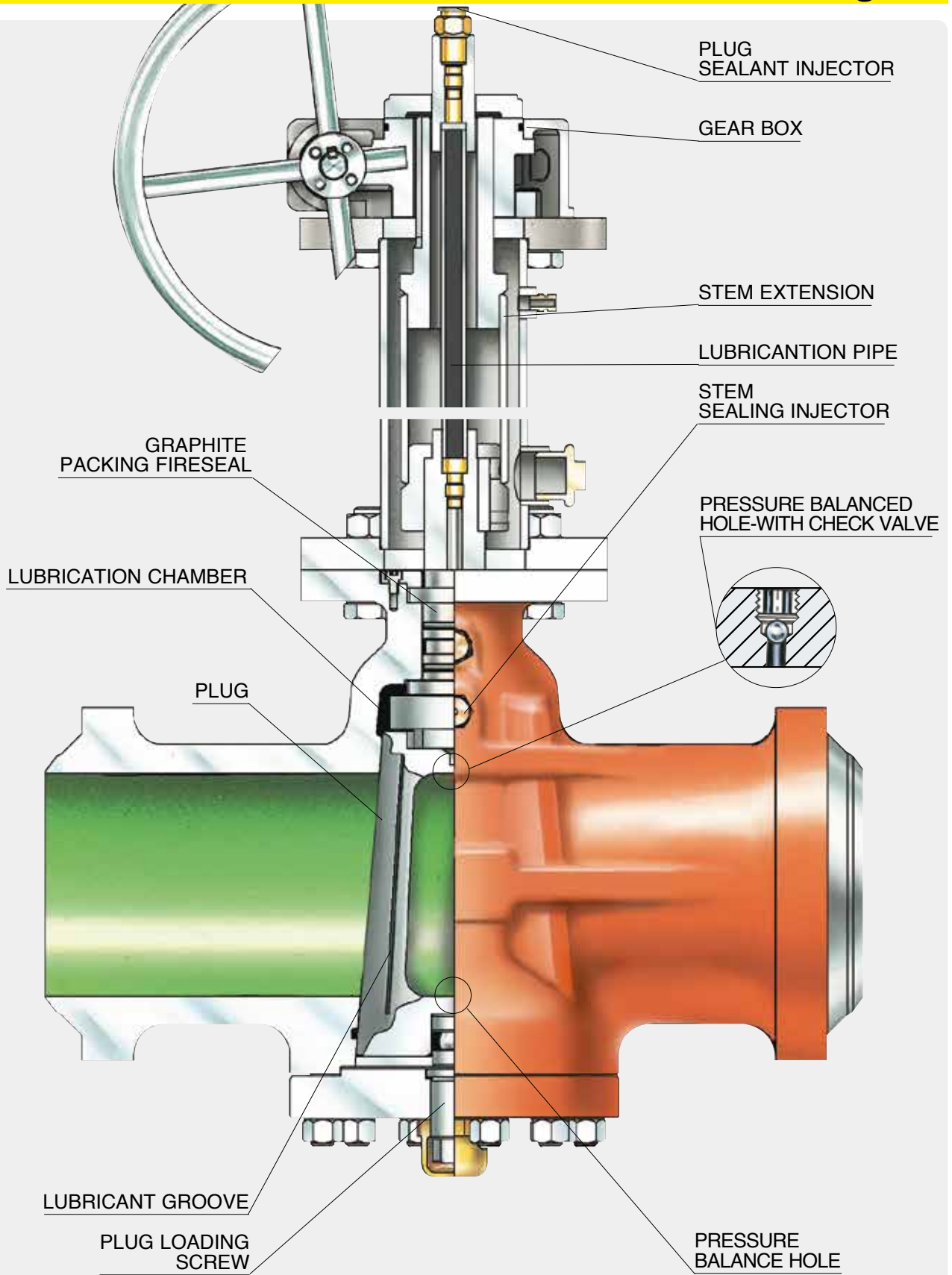

NOTES: Specify the distance required from the valve center - line to the handwheel center - line at the ordering time.



Product Identification System

Identification numbers here shown are used to describe essential features of Galli & Cassina valves.

Example: 300 B R R 06 W P 0001

300

Size

- 1/2" 015 • 3" 080 • 12" 300 • 20" 500
- 3/4" 020 • 4" 100 • 14" 350 • 22" 550
- 1" 025 • 6" 150 • 16" 400 • 24" 600
- 1 1/2" 040 • 8" 200 • 18" 450 • 30" 750
- 2" 050 • 10" 250

B

Valve Type

- **B** Pressure Balanced
- **S*** Standard
- **V*** Standard with Jacket
- **Z*** Standard Full Jacketed

R

Pattern

- **V** Venturi
- **C** Short
- **R** or **W** Regular
- **F**** Full bore
- **K**** Short Full bore

R

Valve Operator Type

- **C** Lever
- **R** Gear
- **E** Gear with Electric Motor
- **A** Actuator (Pneumatic or Gas overoil)
- **B** Bare Stem

06

Working Pressure Class

- | API 6D Valves | | API 6A Valves | |
|---------------|-----------|---------------|------------|
| • 150 01 | • 300 03 | • 2000 20 | • 3000 30 |
| • 400 04 | • 600 06 | • 5000 50 | • 10000 00 |
| • 900 09 | • 1500 15 | • 15000 1K | |
| • 2500 25 | | | |

W

Valve End Connection

- **F** Threaded
- **T** Socket
- **R** RF Flange
- **W** Butt Weld
- **B** Butt Weld by Flange
- **J** Ring Joint Flange
- **C** Clamp

P

Optional Special Features

- **T** Completely Buried
- **P** Partially Buried
- **N** Pups
- **J** Partially Buried and Pups

0001

Internal Material Identification

According to client's materials requirement

The Code used as sample above (300 B R R 06 W P 0001) identifies a: DN 300 (12") - Pressure balanced plug valve - Regular pattern - Gear operated - ANSI 600 (PN 100) - Butt welding ends connection (w.t. according to client's requirement) - Stem extension (length from pipeline center line to the top of the stem extension according to client's requirement) - Standard carbon steel materials suitable for ambient and higher temperature service.

* See G&C blue catalogue "LUBRICATED PLUG VALVES STANDARD & JACKETED TYPE".

** See G&C green catalogue "LUBRICATED PLUG VALVES PRESSURE BALANCED FULL BORE TYPE".

*** See G&C silver catalogue "FULL BORE PRESSURE BALANCED TYPE WITH LGC* LUBRICATION SYSTEM".



ANSI Class 150 to 2500 (PN 20 to PN 420)

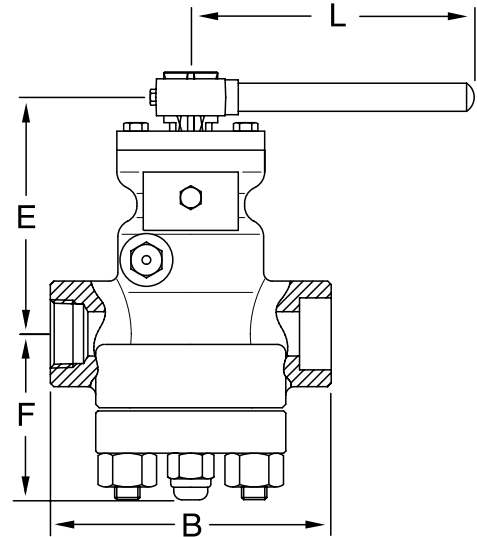
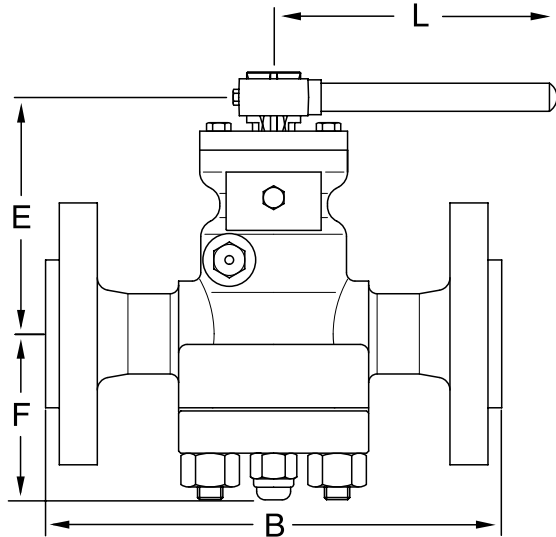

Size	NPS DN	RF Flanged Ends**				Screwed & Socked Ends				
		1/2 15	3/4 20	1 25	1 1/2 40	1/2 15	3/4 20	1 25	1 1/2 40	2 50
Face To Face										
ANSI 150 (PN 20)	B	140*	140*	140*	165	114	114	133	187	267
ANSI 300 (PN 20)	B	140*	152	159	191	114	114	133	187	267
ANSI 600 (PN 100)	B	165	191	216	241	114	114	133	187	292
ANSI 800 (PN 140)	B	-	-	-	-	114	114	133	187	371
ANSI 900-1500 (PN 150/250)	B	216	229	254	305	133	133	133	187	371
ANSI 2500 (PN 420)	B	264	273	308	384	133	133	187	229	451
Top of Stem to Center Line	E	125	125	125	160	125	125	125	160	180
Body Cap to Center Line	F	80	80	80	130	80	80	80	130	100
Length of Wrench	L	300	300	300	500	300	300	300	450	450
Weight kg										
ANSI 150 (PN 20)		8,1	8,2	9,2	17,8	7	7	7,3	15	17
ANSI 300 (PN 50)		8,3	9,4	10,4	20,6	7	7	7,3	15	17
ANSI 600 (PN 100)		8,5	9,8	10,8	21,4	7	7	7,3	17	20
ANSI 800 (PN 140)		-	-	-	-	7	7	7,3	18	21
ANSI 900-1500 (PN 150/250)		12,4	13,5	16,3	28,1	8	8	8,5	21	23
ANSI 2500 (PN 420)		15,6	16,3	20,3	39,7	9	9	11	27	29

NOTES: (*) In case of body in forged material, the face to face dimension is 152 mm.

(**) Available also with Ring Joint, Butt Welding and Clamp end connections.



ANSI Class 150 (PN 20)

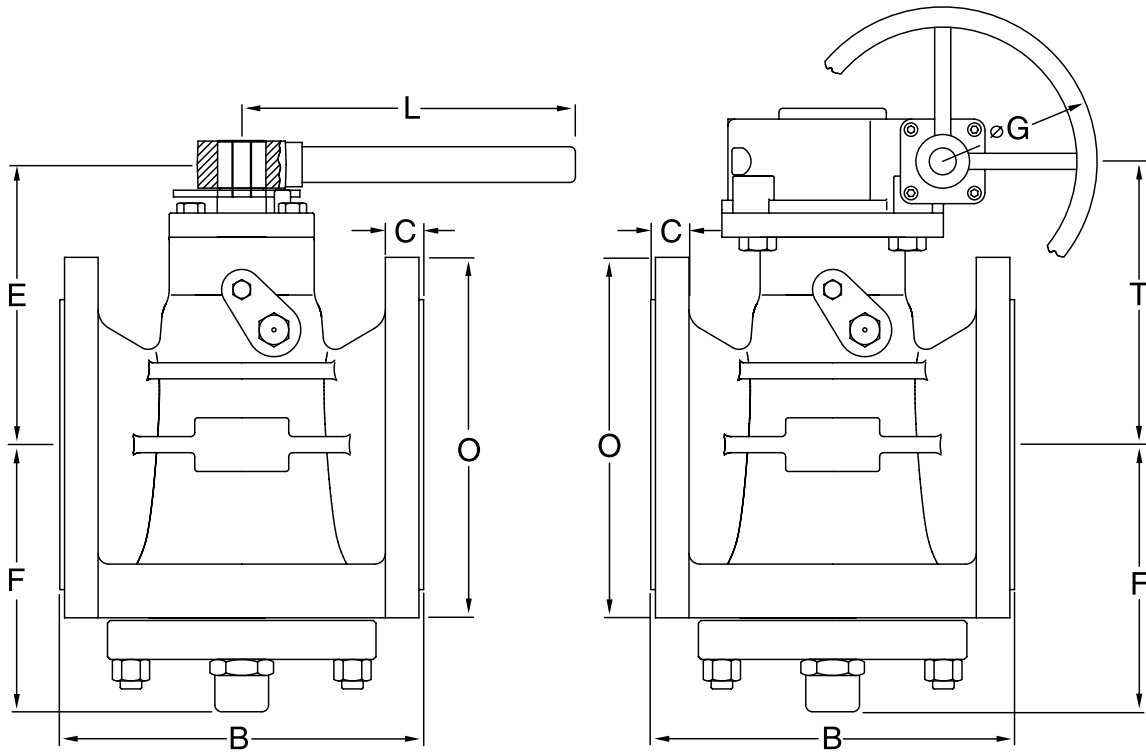

Size	NPS DN	Short Pattern						Regular Pattern				
		2 50	3 80	4 100	6 150	8 200	10 250	12 300	6 150	8 200	10 250	12 300
Face To Face RF	B	178	203	229	267	292	330	356	394	457	533	610
RTJ	B	191	216	241	279	305	343	368	406	470	546	622
BW	B	267	330	356	457	521	559	635	457	521	559	635
Flange Diameter	O	152	191	229	279	343	406	483	279	343	406	483
Flange Thickness	C	16	19	24	26	29	30	32	26	29	30	32
Top of Stem to Center Line	E	180	220	240	250	-	-	-	-	-	-	-
Body Cap to Center Line	F	120	165	180	210	270	320	365	195	250	305	320
Center Line Valve to CL Operator	T	-	-	-	280	320	370	420	280	280	365	375
Handwheel Diameter	G	-	-	-	560	560	560	500	-	-	-	-
Length of Wrench	L	450	500	750	1000	-	-	-	-	-	-	-
Weight RF/RTJ	kg	18	34	53	78	157	220	325	117	175	250	365
Weight BW	kg	15	30	45	67	124	195	290	82	158	215	320

NOTES: Short Pattern valve flanges from NPS 3" to 10" have 2 tapped holes UNC threaded, NPS 12" has 4 tapped holes UNC threaded. NPS 6" available wrench or gear operated.
Handwheel dimension (G) is indicative only.
The exact dimension depends of the maximum breakway force allowed.
The same range of valves is available for Regular Pattern with face to face dimension in accordance with BS5353.



ANSI Class 150 (PN 20)

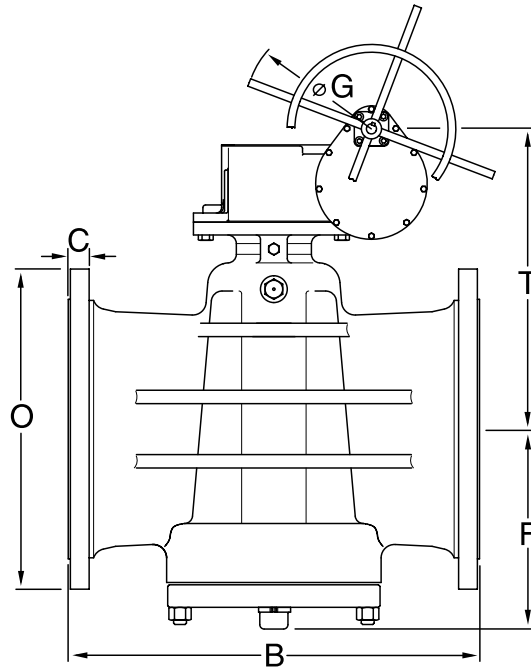

Size	NPS DN	Venturi Pattern									
		10 250	12 300	14 350	16 400	18 450	20 500	24 600	26 650	30 750	36 900
Face To Face											
RF	B	533	610	686	762	864	914	1067	1245	1295	1600
RTJ	B	546	622	699	775	876	927	1080	1258	1308	1613
BW	B	559	635	686	762	864	914	1067	1245	1295	1600
Flange Diameter	O	406	483	533	597	635	699	813	870	984	1168
Flange Thickness	C	30	32	35	37	40	43	48	68	75	90
Body Cap to Center Line	F	320	365	380	400	420	470	530	580	610	850
Center Line Valve to CL Operator	T	370	420	420	420	450	500	550	600	660	910
Handwheel Diameter	G	560	500	500	700	700	700	800	800	800	800
Weight RF/RTJ	kg	220	325	430	760	900	1150	1500	2670	3870	5460
Weight BW	kg	190	270	355	670	795	1010	1350	2350	3490	4920

NOTES: Face to Face of NPS 26"/28" in accordance with API 6D Class 300.
 Face to Face of NPS 30" - 36" in accordance with ASME B16.10.
 Flange dimensions of NPS 26" - 30" - 36" in accordance with MSS-SP44.
 Handwheel dimension (G) is indicative only.
 The exact dimension depends of the maximum breakway force allowed.
 The same range of valves is available for Regular Pattern with face to face dimension in accordance with BS5353.



ANSI Class 300 (PN 50)

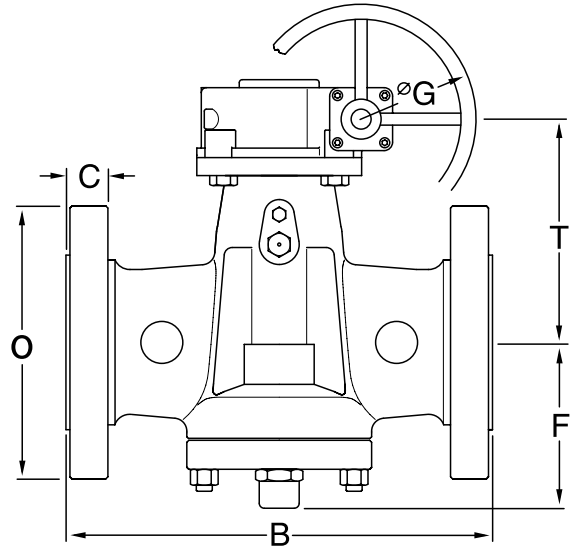
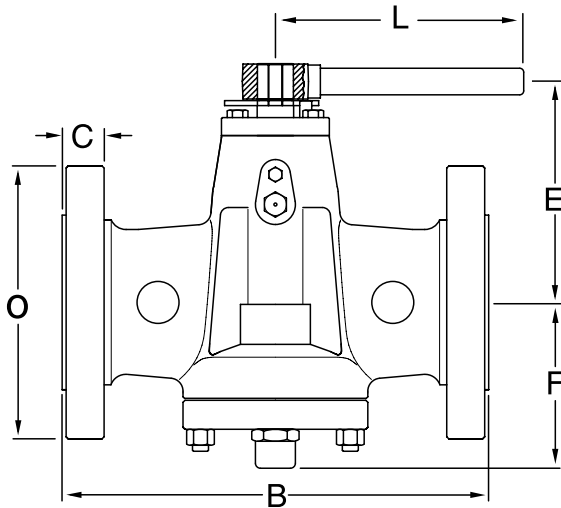

Size	NPS DN	Short Pattern						Regular Pattern			
		2 50	3 80	4 100	6 150	8 200	10 250	12 300	6 150	8 200	10 250
Face To Face											
RF	B	216	283	305	403	419	457	502	403	502	568
RTJ	B	232	298	321	419	435	473	518	419	518	584
BW	B	267	330	356	457	521	559	635	457	521	568
Flange Diameter	O	165	210	254	318	381	445	521	318	381	445
Flange Thickness	C	22	29	32	37	42	48	51	37	42	48
Top of Stem to Center Line	E	180	220	240	250	-	-	-	-	-	-
Body Cap to Center Line	F	115	165	180	220	285	320	400	195	250	310
Center Line Valve to CL Operator	T	-	-	-	280	330	370	370	280	280	350
Handwheel Diameter	G	-	-	-	560	560	560	700	560	560	700
Length of Wrench	L	500	750	750	1000	-	-	-	-	-	-
Weight RF/RTJ	kg	21	39	62	100	180	290	400	150	215	325
Weight BW	kg	16	33	50	80	148	240	330	120	195	290

NOTES: Handwheel dimension (G) is indicative only.

The exact dimension depends of the maximum breakway force allowed.

NPS 6" available wrench or gear operated.

The same range of valves is available for Regular Pattern with face to face dimension in accordance with BS5353.



ANSI Class 300 (PN 50)

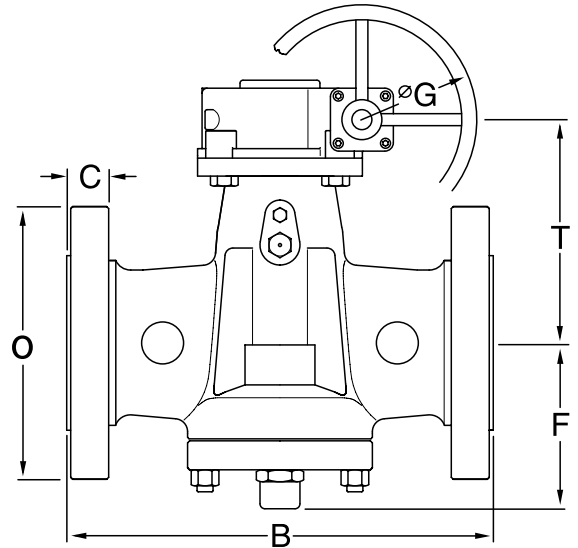
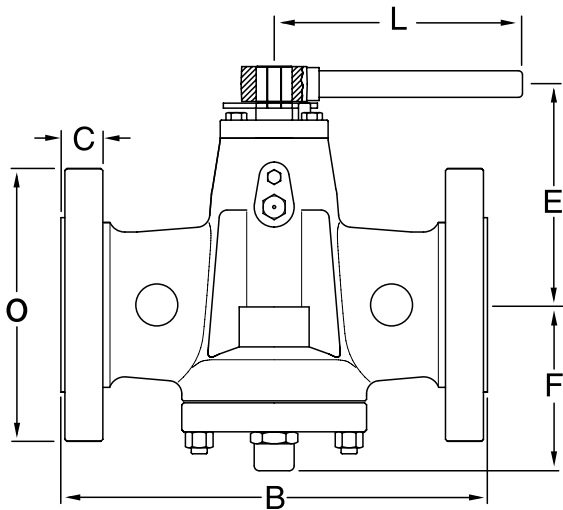

Venturi Pattern

Size	NPS DN	6 150	8 200	10 250	12 300	14 350	16 400	18 450	20 500	24 600	26 650	30 750	36 900
Face To Face													
RF	B	403	419	457	502	762	838	914	991	1143	1245	1397	1727
RTJ	B	419	435	473	518	778	854	930	1010	1165	1270	1422	1756
BW	B	457	521	559	635	762	838	914	991	1143	1245	1397	1727
Flange Diameter	O	318	381	445	521	584	648	711	775	914	972	1092	1270
Flange Thickness	C	37	42	48	51	54	58	61	64	70	84	95	111
Top of Stem to Center Line	E	250	-	-	-	-	-	-	-	-	-	-	-
Body Cap to Center Line	F	220	285	320	380	400	385	460	450	580	580	650	850
Center Line Valve to CL Operator	T	-	330	370	430	445	455	490	580	600	600	780	910
Handwheel Diameter	G	560	560	560	700	700	700	700	800	800	800	800	800
Length of Wrench	L	1000	-	-	-	-	-	-	-	-	-	-	-
Weight RF/RTJ	kg	120	180	270	400	550	694	1100	1370	1900	2400	4500	7470
Weight BW	kg	80	165	240	330	446	560	870	1220	1780	1980	3600	5990

NOTES: NPS 6" available wrench or gear operated.

Flange dimensions of NPS 26" - 30" - 36" in accordance with MSS-SP44.

Handwheel dimension (G) is indicative only.

The exact dimension depends of the maximum breakway force allowed.

The same range of valves is available for Regular Pattern with face to face dimension in accordance with BS5353.



ANSI Class 600 (PN 100)

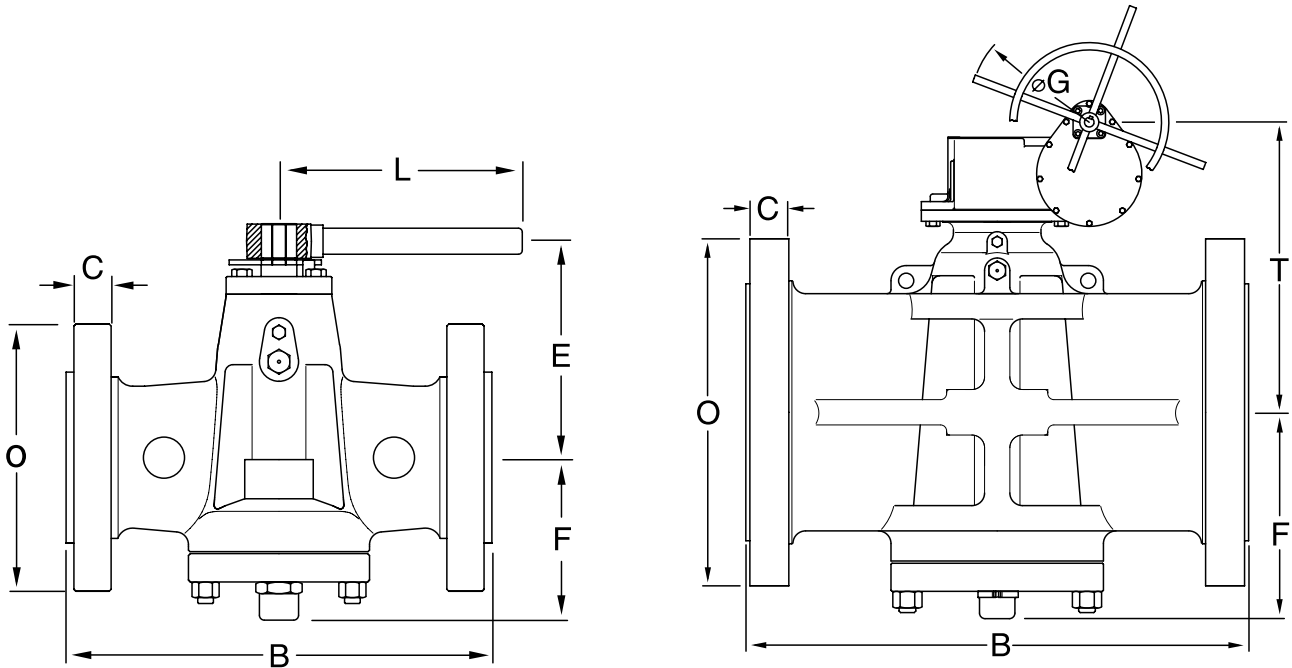

Regular Pattern

Size	NPS DN	2 50	3 80	4 100	6 150	8 200	10 250	12 300	14 350	16 400	20 500	24 600
Face To Face												
RF	B	292	356	432	559	660	787	838	889	991	1194	1397
RTJ	B	295	359	435	562	664	791	841	892	994	1200	1407
BW	B	292	356	432	559	660	787	838	889	991	1194	1397
Flange Diameter	O	165	210	273	356	419	508	559	603	686	813	940
Flange Thickness	C	26	32	38	48	56	64	67	70	76	89	102
Top of Stem to Center Line	E	180	220	240	-	-	-	-	-	-	-	-
Body Cap to Center Line	F	120	145	165	210	275	350	390	420	410	510	610
Center Line Valve to CL Operator	T	-	220	220	270	320	490	420	540	475	610	790
Handwheel Diameter	G	-	-	560	300	300	700	800	800	760	800	800
Length of Wrench	L	500	750	1000	-	-	-	-	-	-	-	-
Weight RF/RTJ	kg	28	47	81	175	290	585	905	1080	1330	2600	4300
Weight BW	kg	22	38	55	125	220	470	735	820	1050	2280	3420

NOTES: NPS 4" available wrench or gear operated.
Handwheel dimension (G) is indicative only.
The exact dimension depends of the maximum breakway force allowed.



ANSI Class 600 (PN 100)

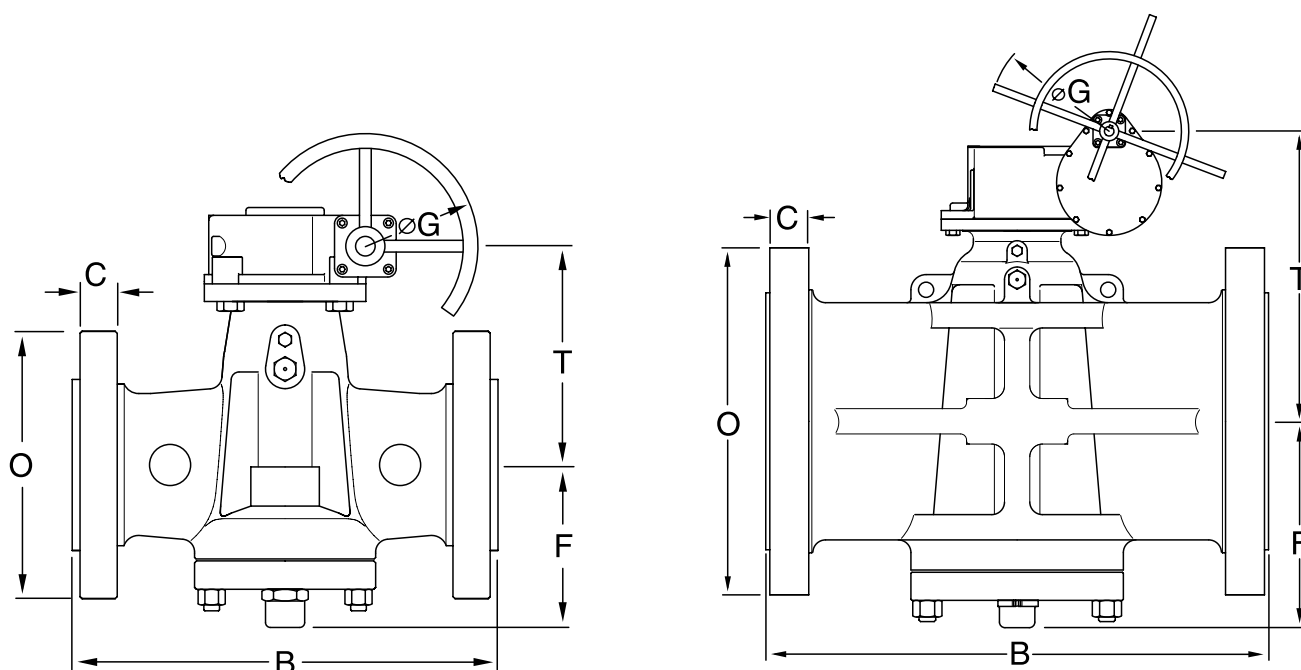

Venturi Pattern

Size	NPS DN	6 150	8 200	10 250	12 300	14 350	16 400	18 450	20 500	24 600	26 650	28 700	30 750	36 900
Face To Face														
RF	B	559	660	787	838	889	991	1092	1194	1397	1448	1549	1651	2083
RTJ	B	562	664	791	841	892	994	1095	1200	1407	1461	1562	1664	2099
BW	B	559	660	787	838	889	991	1092	1194	1397	1448	1549	1651	2083
Flange Diameter	O	356	419	508	559	603	686	743	813	940	1016	1073	1130	1314
Flange Thickness	C	48	56	64	67	70	77	83	89	102	108	111	114,5	124
Body Cap to Center Line	F	245	245	310	350	380	410	410	470	510	615	625	670	710
Center Line Valve to CL Operator	T	290	300	370	490	425	540	480	635	610	790	810	835	890
Handwheel Diameter	G	560	300	700	700	700	700	760	800	800	900	900	900	900
Weight RF/RTJ	kg	162	260	500	715	920	1100	1650	2080	3010	4260	5475	6690	11150
Weight BW	kg	112	190	410	580	730	870	1400	1670	2420	3700	4750	5800	8750

NOTES: Handwheel dimension (G) is indicative only.
 The exact dimension depends of the maximum breakway force allowed.
 Flange dimensions of NPS 26" - 28" - 30" - 36" in accordance with MSS-SP44.



ANSI Class 900 (PN 150)

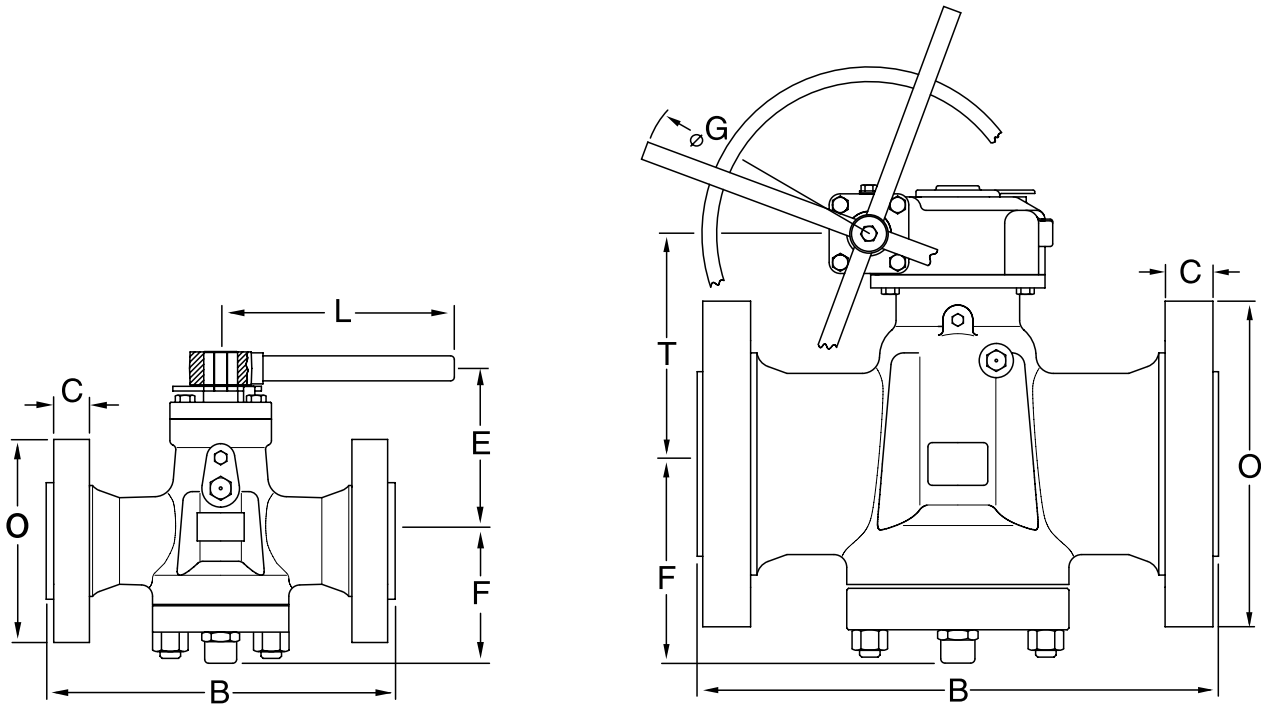

Size	NPS DN	Regular Pattern						Venturi Pattern						
		2 50	3 80	4 100	6 150	8 200	10 250	12 300	14 350	16 400	20 500	24 600	28 700	30 750
Face To Face														
RF	B	368	381	457	610	737	838	965	1029	1130	1321	1549	1753	1880
RTJ	B	371	384	460	613	740	841	968	1038	1140	1334	1568	1775	1902
BW	B	368	381	457	610	737	838	965	1029	1130	1321	1549	1753	1880
Flange Diameter	O	216	242	292	381	470	546	610	642	705	857	1041	1169	1232
Flange Thickness	C	38	38	45	56	64	70	80	86	89	108	140	172	183
Top of Stem to Center Line	E	210	220	240	-	-	-	-	-	-	-	-	-	-
Body Cap to Center Line	F	140	180	190	255	275	320	380	430	470	500	580	655	700
Center Line Valve to CL Operator	T	-	-	250	290	310	430	450	495	590	600	635	950	820
Handwheel Diameter	G	-	-	560	560	560	700	700	700	800	800	800	1000	800
Length of Wrench	L	500	1000	1000	-	-	-	-	-	-	-	-	-	-
Weight RF/RTJ	kg	50	80	145	220	380	580	1080	1250	1505	2830	4380	7660	9670
Weight BW	kg	36	65	125	145	294	460	720	920	1250	2370	3190	7270	7750

NOTES: NPS 6" up to 24" valves available in Regular Pattern.
 NPS 4" available wrench or gear operated.
 Face to Face of NPS 14" - 20" - 24" in accordance with ASME B16.10
 Handwheel dimension (G) is indicative only.
 The exact dimension depends of the maximum breakway force allowed.
 Flange dimensions of NPS 28"-30"-36" in accordance with MSS-SP 44



ANSI Class 1500 (PN 250)

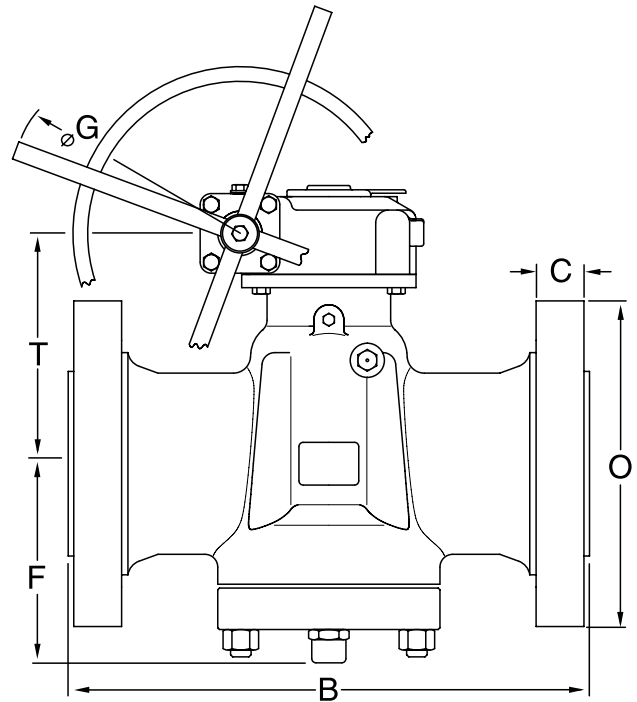
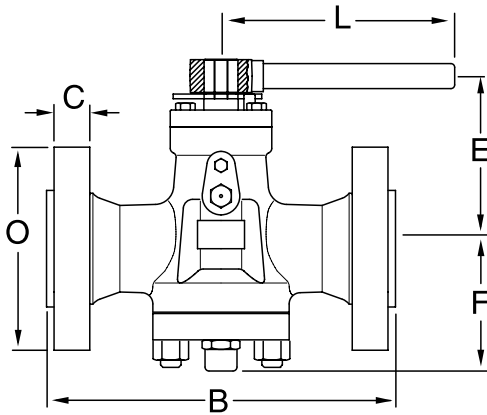

Size	NPS DN	Regular Pattern				Venturi Pattern							
		2 50	3 80	4 100	6 150	8 200	10 250	12 300	14 350	16 400	20 500	24 600	
Face To Face													
RF	B	368	470	546	705	832	991	1130	1257	1384	1664	1943	
RTJ	B	371	473	549	711	841	1000	1146	1276	1406	1686	1972	
BW	B	368	470	546	705	832	991	1130	1257	1384	1664	1943	
Flange Diameter	O	216	267	311	394	483	584	673	749	825	984	1168	
Flange Thickness	C	38	48	54	83	92	108	124	133	146	178	203	
Top of Stem to Center Line	E	210	235	-	-	-	-	-	-	-	-	-	
Body Cap to Center Line	F	140	190	210	250	280	390	440	490	530	560	600	
Center Line Valve to CL Operator	T	-	235	270	270	370	400	530	580	610	640	670	
Handwheel Diameter	G	-	-	560	560	700	700	700	800	800	800	800	
Length of Wrench	L	750	1000	-	-	-	-	-	-	-	-	-	
Weight RF/RTJ	kg	50	95	170	305	590	950	1720	2050	2950	4500	5394	
Weight BW	kg	36	67	150	248	460	740	1260	1340	2350	3600	4550	

NOTES: NPS 6" up to 24" valves available in Regular Pattern.
 Handwheel dimension (G) is indicative only.
 The exact dimension depends of the maximum breakway force allowed.
 Face to Face of NPS 14" - 16" - 20" - 24" in accordance with ASME B16.10.



ANSI Class 2500 (PN 420)

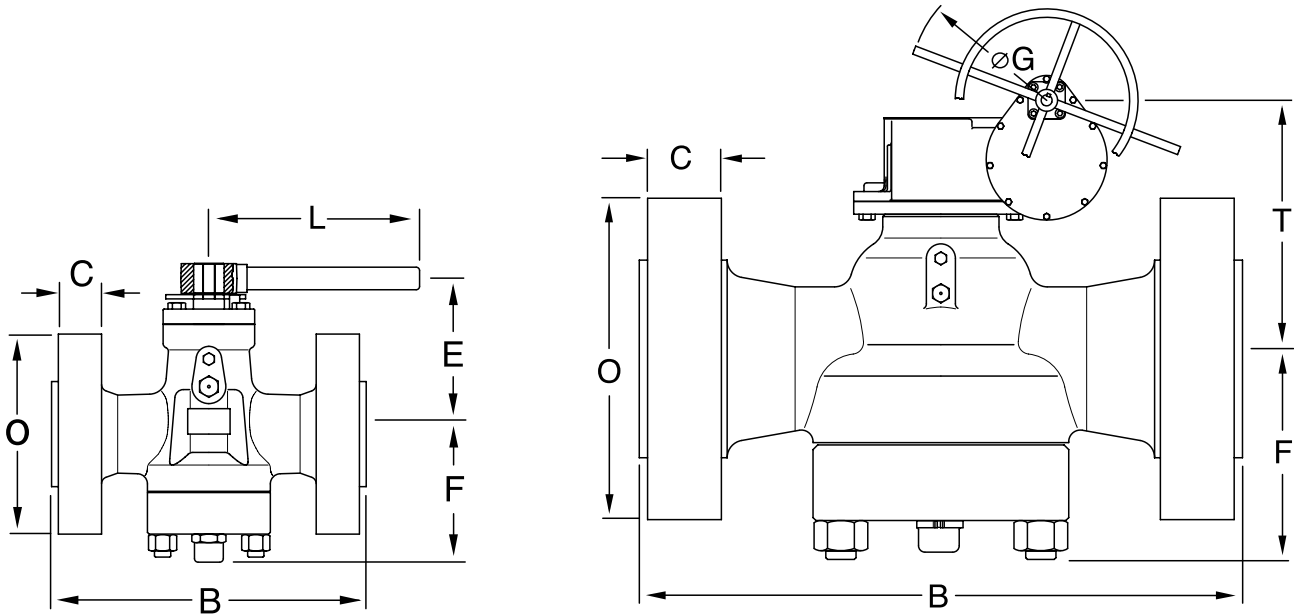

Regular Pattern

Size	NPS DN	2 50	3 80	4 100	6 150	8 200	10 250	12 300
Face To Face								
RF	B	451	578	673	914	1022	1270	1422
RTJ	B	454	584	683	927	1038	1292	1445
BW	B	451	578	673	914	1022	1270	1422
Flange Diameter	O	235	305	356	483	552	673	762
Flange Thickness	C	51	67	76	108	128	165	185
Top of Stem to Center line	E	200	-	-	-	-	-	-
Body Cap to Center Line	F	160	210	240	290	330	350	400
Center Line Valve to CL Operator	T	-	190	230	290	370	500	700
Handwheel Diameter	G	-	560	560	700	800	800	800
Length of Wrench	L	1000	-	-	-	-	-	-
Weight RF/RTJ	kg	72	140	240	600	1300	2100	3000
Weight BW	kg	48	89	150	420	980	1560	2150

NOTES: NPS 2" available wrench or gear operated.
 Handwheel dimension (G) is indicative only.
 The exact dimension depends of the maximum breakway force allowed.



Pressure Balanced Plug Valves

API 6A 2000-3000-5000-10000

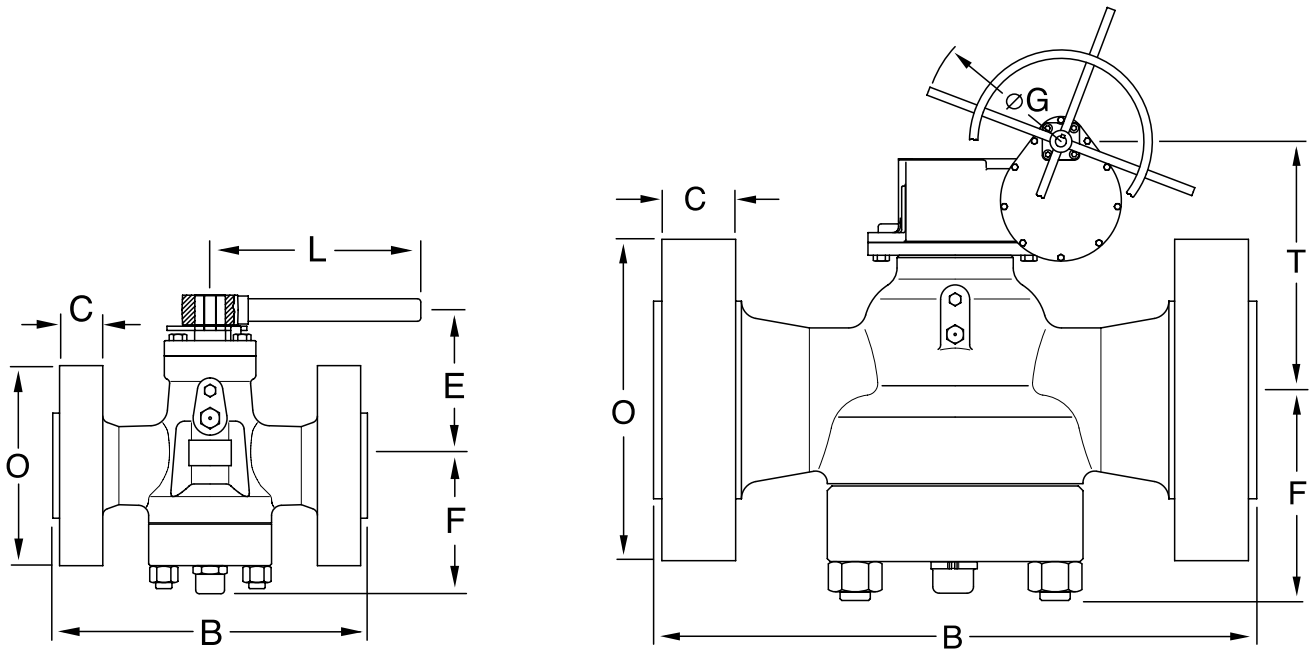

Size	NPS DN	API 2000 - Regular					API 3000 - Regular				
		2 ¹ / ₁₆ 52	2 ⁹ / ₁₆ 65	3 ¹ / ₈ 79	4 ¹ / ₁₆ 103	7 ¹ / ₁₆ 179	2 ¹ / ₁₆ 52	2 ⁹ / ₁₆ 65	3 ¹ / ₈ 78	4 ¹ / ₁₆ 103	7 ¹ / ₁₆ 179

Face To Face												
RTJ	B	295	333	359	435	562	371	422	384	460	613	
Flange Diameter	O	165	190	210	273	356	216	245	241	292	381	
Flange Thickness	C	26	29	32	38	48	38	42	38	45	56	
Top of Stem to Center Line	E	180	180	220	-	-	180	180	218	-	-	
Body Cap to Center Line	F	120	120	150	170	200	150	130	170	175	200	
Center Line Valve to CL Operator	T	-	-	-	270	280	-	-	-	270	260	
Handwheel Diameter	G	-	-	-	560	560	-	-	-	560	560	
Length of Wrench	L	500	750	1000	-	-	750	750	1000	-	-	
Weight	kg	28	35	47	81	175	50	58	80	145	220	

Size	NPS DN	API 5000 - Regular					API 10000 - Full Bore						
		2 ¹ / ₁₆ 52	2 ⁹ / ₁₆ 65	3 ¹ / ₈ 79	4 ¹ / ₁₆ 103	7 ¹ / ₁₆ 179	1 ¹³ / ₁₆ 46	2 ¹ / ₁₆ 52	2 ⁹ / ₁₆ 65	3 ¹ / ₁₆ 78	4 ¹ / ₁₆ 103	5 ¹ / ₈ 130	7 ¹ / ₁₆ x6 ³ / ₈ 179x162

Face To Face														
RTJ	B	371	422	473	549	711	464	521	565	619	670	737	889	899
Flange Diameter	O	216	245	267	311	394	188	200	232	270	316	357	480	480
Flange Thickness	C	38	42	48	54	83	37	38	45	51	62	70	92	92
Top of Stem to Center Line	E	180	210	218	-	-	190	-	-	-	-	-	-	-
Body Cap to Center Line	F	150	180	220	175	225	-	152	172	192	220	270	305	305
Center Line Valve to CL Operator	T	-	-	270	270	265	205	210	220	230	248	350	390	390
Handwheel Diameter	G	-	-	280	560	710	-	-	-	710	710	710	800	800
Length of Wrench	L	750	1000	-	-	-	450	750	1000	-	-	-	-	-
Weight	kg	55	65	105	205	330	52	94	169	305	550	950	1700	1800



Hydraulic Pressure Test Duration *In accordance with API 6D and API 598*

Valve Size		Test Duration		Valve Size		Test Duration	
DN (mm)	NPS (Inches)	Shell	Seat (1)	DN (mm)	NPS (Inches)	Shell	Seat (1)
API 598				API 6D / ISO 14313			
15 - 50	1/2 - 2	15 sec.	15 sec.	15 - 100	1/2 - 4	2 min.	2 min.
65 - 150	2 1/2 - 6	60 sec.	60 sec.	150 - 250	6 - 10	5 min.	5 min.
200 - 300	8 - 12	120 sec.	120 sec.	300 - 450	12 - 18	15 min.	5 min.
350 and over	14 and over	300 sec.	120 sec.	500 and over	20 and over	30 min.	5 min.

(1) Duration applicable also for the pneumatic seat test (5.5 bar/80 psi).

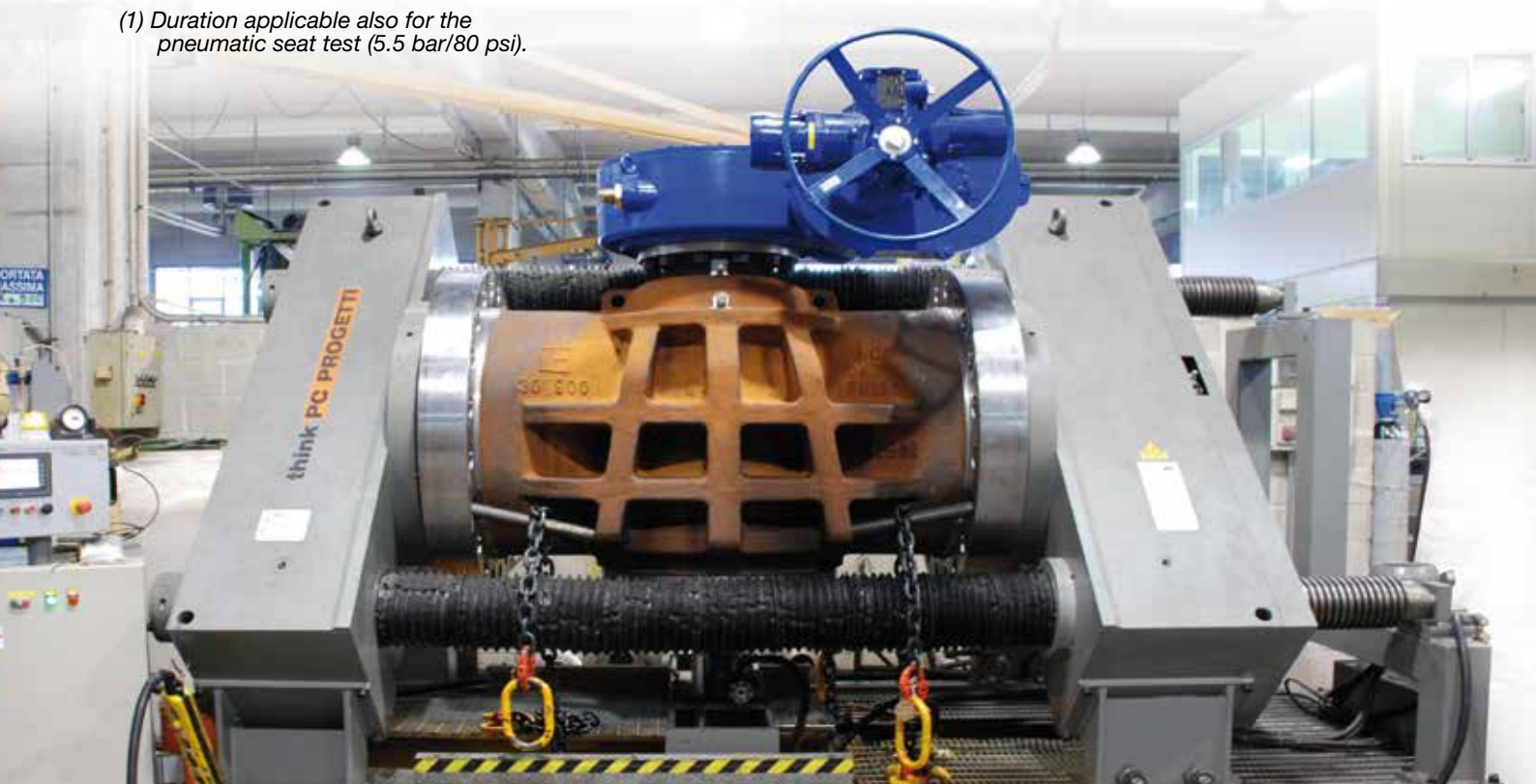

Marking

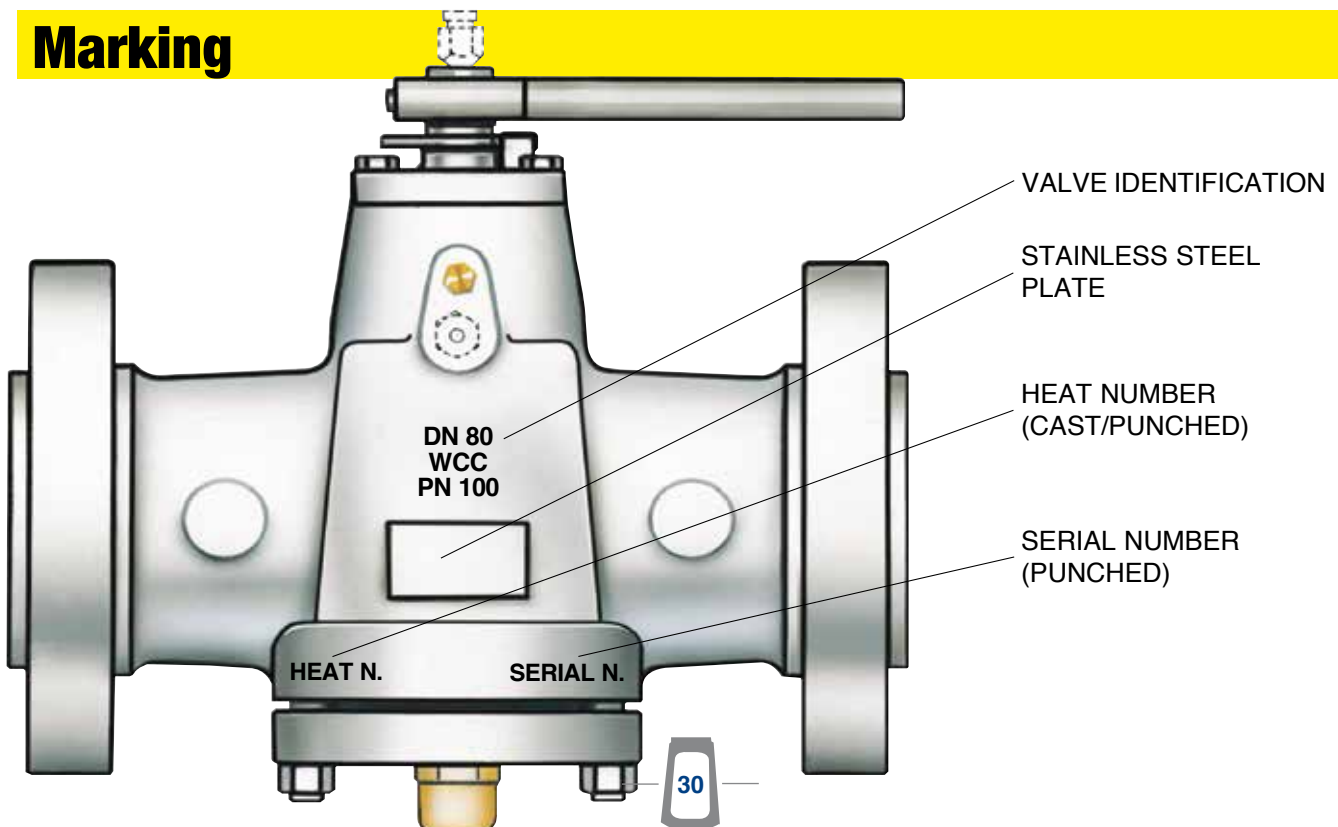



Pressure Test Tables in Accordance with API 598 & API 6D

ASME B16.34 Group Material 1.1

(A 105; A 216 WCB; A 350 LF2)

Working Pressures by Classes, psig (Bar)

	150 PN20	300 PN50	600 PN100	900 PN150	1500 PN250	2500 PN420
Working pressure rating	285 (20)	740 (51)	1480 (102)	2220 (153)	3705 (255)	6170 (425)
Hydraulic body test	450 (31)	1125 (78)	2225 (153)	3350 (231)	5575 (384)	9275 (640)
Hydraulic seat test	314 (22)	814 (56)	1628 (112)	2442 (168)	4076 (281)	6787 (468)

ASME B16.34 Group Material 1.2 and 2.8

(A 350 LF6; A 216 WCC; A 352 LCC; A182 F44/ F51; UNS S31803/S31254/S32750; A 351 Gr. CK3MCuN / CE8MN/ CD4MCu / CD3MWCuN)

Working Pressures by Classes, psig (Bar)

	150 PN20	300 PN50	600 PN100	900 PN150	1500 PN250	2500 PN420
Working pressure rating	290 (20)	750 (52)	1500 (103)	2250 (155)	3750 (259)	6250 (431)
Hydraulic body test	450 (31)	1125 (78)	2250 (155)	3375 (233)	5625 (388)	9375 (646)
Hydraulic seat test	319 (22)	825 (57)	1650 (114)	2475 (171)	4125 (284)	6875 (474)

ASME B16.34 Group Material 1.3

(A 352 LCB)

Working Pressures by Classes, psig (Bar)

	150 PN20	300 PN50	600 PN100	900 PN150	1500 PN250	2500 PN420
Working pressure rating	265 (18)	695 (48)	1390 (96)	2085 (144)	3470 (239)	5785 (399)
Hydraulic body test	400 (28)	1050 (72)	2100 (145)	3150 (217)	5225 (360)	8700 (600)
Hydraulic seat test	292 (20)	765 (53)	1529 (105)	2294 (158)	3817 (263)	6364 (439)

ASME B16.34 Group Material 2.1 and 2.2

(A 182 F304; A 479 Gr. 304; A 351 CF3; A 351 CF8; A 182 F316; A 479 Gr. 316; A 351 CF3M)

Working Pressures by Classes, psig (Bar)

	150 PN20	300 PN50	600 PN100	900 PN150	1500 PN250	2500 PN420
Working pressure rating	275 (19)	720 (50)	1440 (99)	2160 (149)	3600 (248)	6000 (414)
Hydraulic body test	425 (29)	1100 (76)	2175 (150)	3250 (224)	5400 (372)	9000 (621)
Hydraulic seat test	303 (21)	792 (55)	1584 (109)	2376 (164)	3960 (273)	6600 (455)

ASME B16.34 Group Material 2.3

(A 182 F304/F316L; A 479 Gr. 304/316L)

Working Pressures by Classes, psig (Bar)

	150 PN20	300 PN50	600 PN100	900 PN150	1500 PN250	2500 PN420
Working pressure rating	230 (16)	600 (41)	1200 (83)	1800 (124)	3000 (207)	5000 (345)
Hydraulic body test	350 (24)	900 (62)	1800 (124)	2700 (186)	4500 (310)	7500 (517)
Hydraulic seat test	253 (17)	660 (46)	1320 (91)	1980 (137)	3300 (228)	5500 (379)

Pressure Test Tables in Accordance with API 6A

Working Pressure Rating	Body						Seat	High Pressure Gas Test Body & Seat	
	Up to 13 5/8"			From 16 3/4"				Bar	psi
Bar	psi	Bar	psi	Bar	psi	Bar	psi	Bar	psi
138	2000	276	4000	207	3000	138	2000	138	2000
207	3000	415	6000	310	4500	207	3000	207	3000
345	5000	517	7500	517	7500	345	5000	345	5000
690	10000	1035	15000	1035	15000	690	10000	690	10000
1035	15000	1550	22500	1550	22500	1035	15000	1035	15000
1380	20000	2070	30000			1380	20000	1380	20000

Quality Assurance Programme

CERTIFICATE OF APPROVAL

This is to certify that the Occupational Health & Safety Management System of:

Galli & Cassina S.p.A.
Via Drizza, 30/32
20020 Solaro (Milano) - Italy

has been approved by Lloyd's Register Quality Assurance to the following standard:

OHSAS 18001:2007

The Occupational Health & Safety Management System is applicable to:

Design & manufacturing of plug valves of the after sales services, in carbon steel and exotic special alloys with DN from 6 to DN 900, up to class ANSI 2500 (PN 42) and with DN from 1" 3/16 to 11" up to class API 10000 P and flow indicators and gear operators.

Approval Certificate
No: LRC 6017612/OHS/U/EN



CERTIFICATE OF APPROVAL

This is to certify that the Environmental Management System of:

Galli & Cassina S.p.A.
Via Drizza, 30/32
20020 Solaro (Milano) - Italia

has been approved by Lloyd's Register Quality Assurance to the following Environmental Management System Standard:

ISO 14001:2004

The Environmental Management System is applicable to:

Design & manufacturing of plug valves, including the after sales services, in carbon steel, alloy steel and exotic special alloys with DN from 1/4" up to 36" (i.e. from DN 6 to DN 900), up to class ANSI 2500 (PN 42) and with DN from 1" 3/16 to 11" up to class API 10000 P and flow indicators and gear operators.

Original Approval: 18th March 2014

Approval Certificate
No: LRC 6017612/EMS/U/EN

Certificate of Authority to use the Official API Monogram

License Number: 6A-0520

The American Petroleum Institute hereby grants to:

GALLI & CASSINA S.P.A.
Via Drizza, 30/32
Solaro, Milan
Italy

the right to use the Official API Monogram on manufactured products under the conditions in the official publications of the American Petroleum Institute entitled API Spec Q1[®] and API Spec 6A[®] and in accordance with the provisions of the License Agreement.

In all cases where the Official API Monogram is applied, the API Monogram should be used in conjunction with this certificate number: 6A-0520.

The American Petroleum Institute reserves the right to revoke this authorization to use the Official API Monogram for any reason satisfactory to the Board of Directors of the American Petroleum Institute.

The scope of this license includes the following product: Plug Valves at PSL 1 through 4

QMS Exclusions: No Exclusions Identified as Applicable

American Petroleum Institute
John Madala
Director of Training and Certification Programs





Quality Assurance System

After 95 years of manufacturing experience and latest technology, **Galli&Cassina** Quality Assurance System has been assessed, approved and certified against the following quality assurance standards: ISO 9001-Vision 2000 and API Q1. Rigorous procedures and internal audits guarantee that the Quality System is implemented at all stages, starting from incoming raw materials, production, inspection, assembly, final test, packing and shipping.

Every product is designed and manufactured to conform to uniformly high standards. These standards are assured by a quality management system which includes ISO 9001 certification and testing of all products prior to shipment. Advanced design, durable construction materials and rigid manufacturing standard provide valves you can rely on for years of trouble-free performance. Since its beginning in



1919, **Galli&Cassina** has maintained its commitment to quality product and satisfied customers. Our focus on product variety, technical expertise and company support remains constant, from drawing board to user satisfaction, our commitment is continuous.

Quality Assurance Development

Galli&Cassina's Quality Assurance System ISO 9001-2008 - HSE ISO 14001 & ISO 18001 have been assessed, approved and certified by Lloyd's Register, while the API 6D and API 6A monograms have been certified by API (American Petroleum Institute): all the certificates are the result of **Galli&Cassina's** dedication towards the aim of good reputation in the world-wide valve market, since 95 years.

In addition **Galli&Cassina** Plug Valves are in compliance with CE Pressure Equipment Directive PED N. 97/23/EC and ATEX (N. 94/9/EC) for products intended for use in potentially explosive atmospheres.



Customer Service

Galli&Cassina's Customer Service is always willing to assist the customer with a prompt response to "service" requests. Full after sales services assistance can be offered either at our workshop or on site, spare parts supply. Training programs, on operation and safety.
**Cina - UAE - Kuwait
Saudi Arabia - Europe
India - U.S.A - Canada
Venezuela - Colombia
Brasil.**





Lubricants

Galli&Cassina Plug Valves can use different types of Climax lubricant grease suitable for various services. The operating conditions must be specified at enquiry stage enabling us to advise which type of sealant is suitable. The lubricant grease is available as a spare part item and can be ordered as:



- **Cartridges (suitable for hydraulic gun pump).**
- **Drums (suitable for pneumatic pump). For the selection of the correct lubricant, Galli&Cassina staff is always available at the customer's request to recommend the suitable lubricant.**

Climax Hydraulic Gun No.1699



This specially designed, high pressure handgun, light in weight (appr. 16lbs.) is more rugged than conventional types and meets exacting demands of plug valve sealants. Built for servicing plug valves, all parts are machined with minutye accuracy.

The polished hardened steel piston is perfectly fitted in the high pressure barrel to provide absolute smoothness of operation. The CLIMAX 1699 is self-priming and can be used in any position. Because of its hydraulic principle, this gun exerts more pressure than any other portable gun.

This gun is equipped with a CLIMAX 1699 Button Head Coupler for connection to the button head sealant fitting in the shank of the valve. This coupler has a built-in feature which locks it to fitting when the gun is under positive pressure.

The coupler cannot be connected to or separated from the fitting with the gun under pressure. This pressure may be relieved by a turn of the by-pass valve on the gun. The by-pass valve should not be closed to a point where it is jammed into its seat, nor should it be opened tight against the stop.



The valve should be closed firmly, but no tightly. It is not necessary to open the valve past one full turn. Due to "built-in" safety features, the CLIMAX 1699

provides the maximum safety to both the valve and the gun itself. The hydraulic system of the gun is equipped with a relief fitting to protect

the gun from injury if the operator were to continue to pump after the gun had been depleted of valve sealant.

Also, to prevent damage to the valve and sealant gun, in the event of sealant clogging the system or the operator pumping too fast, a CLIM 0 psi gauge is optional equipment.

This accessory indicates the point at which sufficient sealant pressure has been developed within the valve. The gauge also indicates valve adjustment and other services required.

The CLIMAX 0-15000 psi gauge is the highest quality, most reliable glycerin filled gauge available.

The one piece die cast brass case and heavy duty bourdon tube and movement enable the gauge to stand up to the shock and vibration encountered on the most demanding applications. The CLIMAX gauge also features a rubber gauge protector.

A carrying case for the CLIMAX Model 1699 is optional.

Refer to the part list for available options.

Note: Gun shown is a 1699-S model complete with hose assembly, gauge, tee and "Z" swivel.

Automatic Lubrication

Galli&Cassina Plug Valves can be provided with a special automatic lubricant pump to facilitate lubrication maintenance service.

The automatic pump model depends on the size of valve and its number of open/closed cycles enables

us to calculate the consumption of the lubricant grease during the operating service.

The automatic pumps are available either electric or pneumatic motor type at the following operating temperature range: -20 to 40°C.



Climax Lubricants

Lubricant and No.	Type Available	Color	Temp. Range From To	Principal Services	Unsuitable For
220	Stick Bulk	Clear	-75 to 250 °F -59 to 121 °C	Very cold service for pipe lines, compressor stations, gasoline plants and crude oil production fields. For Liquid Service.	Aromatic, Solvents.
262	Stick		-85 to 250 °F -65 to 121 °C	Same as above-Gas Service.	LPG
400	Stick Bulk	Red	-20 to 450 °F -29 to 232 °C	Acids and Caustics.	Liquid Hydrocarbons.
600	Stick Bulk	Tan Brown	-20 to 500 °F -29 to 260 °C	General gas and general Hydrocarbons service.	LPG
650	Stick Bulk	Blue-Green	-40 to 500 °F -40 to 260 °C	Hydrocarbon and L.P.G. service	Aromatic, Alkalies Solvents.
711	Stick Bulk	White	32 to 400 °F 0 to 204 °C	Aviation gasoline, Jet fuel, fuel blends of Alkylate.	100% Benzine.
750	Stick Bulk	Black	0 to 600 °F -18 to 316 °C	Asphalt hot oil service Salt brine, high temperature steam.	Aromatic, Alkalies Solvents.
800	Stick Bulk	White	-20 to 450 °F -29 to 232 °C	Butane, Butadiene, Carbon Tetrachloride, Ethane, Propane.	Alkalies
900	Stick Bulk	Black	-20 to 650 °F -29 to 343 °C	Natural gas, petrochemical plants, rubber plants, and hot Hydrocarbons service.	Alkalies
901	Stick Bulk	Black	-30 to 300 °F -34 to 149 °C	Cold weather, Hydrocarbon lubricant.	Alkalies
950	Stick Bulk	Amber	-40 to 300 °F -40 to 149 °C	Propylenes, Benzenes Toulene, Butadiene, Xylenes, Styrene, Cumenes	Alkalies
1034-MT	Stick Bulk	Cream	-20 to 400 °F -29 to 204 °C	Liquid and gaseous. Aliphatic hydrocarbon service. (Wet or dry natural gas)	Alkalies



Routine Maintenance Instructions

Galli&Cassina valves are designed to require the minimum of maintenance. If a valve is operated infrequently or not at all, then it is good practice to exercise it occasionally by moving the plug even partially. To ensure maximum valve life and performance, Galli&Cassina recommend the occasional injection of plug lubricant. Periodic plug lubricant injection may be needed to keep the valve operating

torque from increasing and to maintain bubble tight sealing. It is important to use only plug lubricant recommended by Galli&Cassina. A wrong lubricant selection can:

- A) Cause valve leakage.
- B) Cause valve seizure.
- C) Require valve disassembling for lubricant removing and cleaning.

Frequency of Lubrication:

This depends on the frequency of valve operation, operating conditions and the mechanical condition of the valve.

The following lubrication schedule could be an useful guide:

- After a period of 12 months with valve kept in open/closed position.

- 10 to 100 operations per week: daily.
- Up to 10 operations per week: weekly.
- Up to 10 operations per year: monthly.
- Less frequently: twice annually.

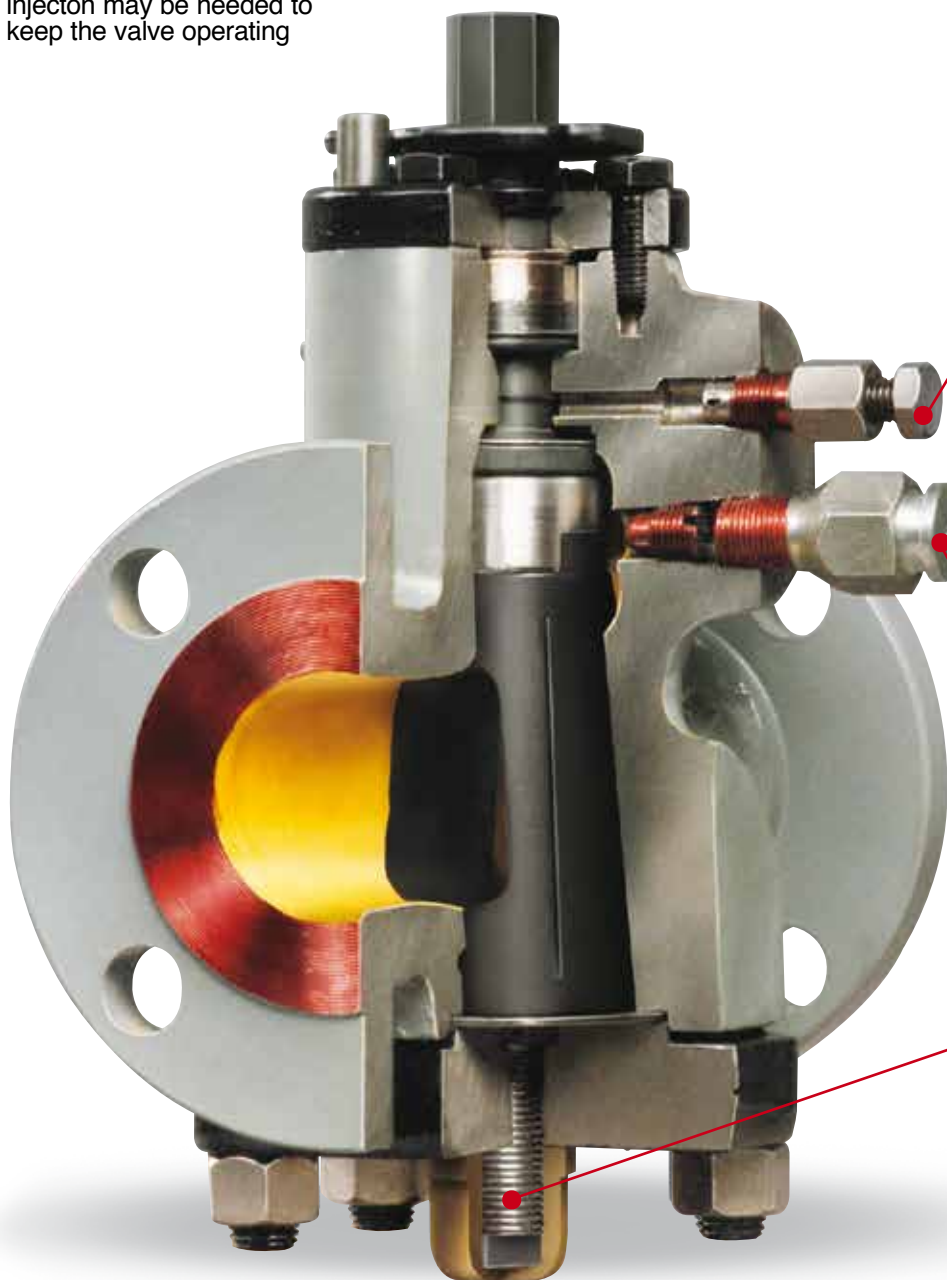

Galli&Cassina Plug Valves usually do not require further mastic injection after workshop assembling. In the event of leakage to atmosphere occurring around the stem, it can be stopped by injecting stem sealing compound at the stem sealing injector.

Galli&Cassina recommend a periodic lubrication of the plug surface to keep low torque and bubble tight sealing. Lubricant injector, giant button head type, usually located on the side of the body valve, can in peculiar cases be placed on the top of the stem. The use of Climax hydraulic pump 1699 type is recommended.

The plug loading screw is normally set up during the assembling of the valve and it **must be always kept tightened** for all the operating time.

It is very important to lubricate periodically the valve using Climax lubricant or other lubricants approved by Galli&Cassina.



Engineering Data



Design

Galli&Cassina Plug Valves have been designed in accordance with International STD. norms.
ASME B16.34 - API 599 - API 6D - API 6A - BS 5353.
The stem is anti-blow-out design and incorporates three sealing system (two o-rings and one stem packing). Graphite gasket is provided to guarantee full accordance with Fire Safe API 6FA and BS 6755-Part 2 specification.
Fire Safe Test Certificate is available upon request.

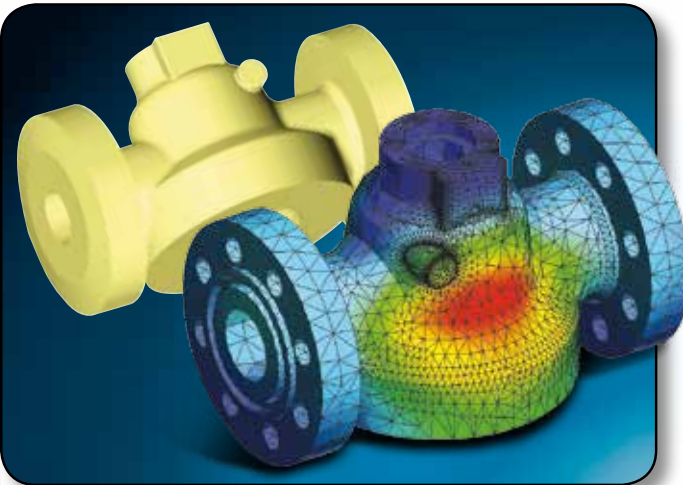
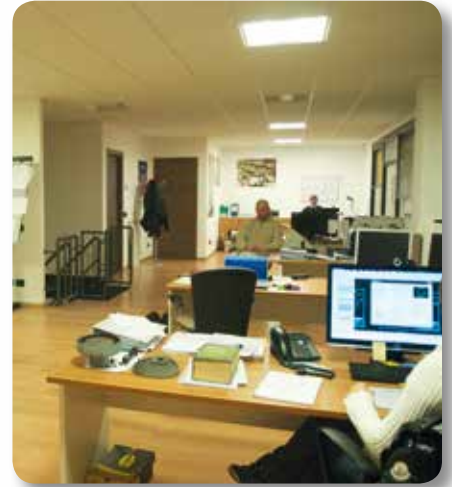



Conversion Tables

To Convert Into Multipli by

A

Atmosphere	bar	1,01325
Atmosphere	cms. of mercury	76.0
Atmosphere	ft. of water (at 4°C)	33.90
Atmosphere	in. of mercury (at 0°C)	29.92
Atmosphere	kgs./sq. cm.	1.0333
Atmosphere	pounds/sq. in.	14.70
Atmosphere	pascal (N/m ²)	98070

B

Bar	atmosphere	1.0197
Bar	psi	14.505
Bar	pascal	105
Barrels(U.S.,liquid)	gallons	31.5
Barrels (oil)	gallons (oil)	42.0
Btu	foot - lbs.	778.3
Btu	gram-calories	252.0
Btu	horsepower-hrs.	3.931 x 10 ⁻⁴
Btu/hr	kilowatt-hrs	2.928 x 10 ⁻⁴
Btu/hr	horsepower	3.931 x 10 ⁻⁴
Btu	Watts	0.2931

C

Calories, gram (mean)	B.T.U. (mean)	3.9685 x 10 ⁻³
Centigrade	Fahrenheit	(C° 9/5)+32
Centimeters	feet	3.281 x 10 ⁻²
Centimeters	inches	0.3937
Centimeters	mils	393.7
Centimeters of mercury	atmospheres	0.01316
Centimeters of mercury	feet of water	0.4461
Centimeters of mercury	pounds/sq. in.	0.1934
Circumference	radians	6.283
Cubic centimeters	cu. feet	3.531 x 10 ⁻⁵
Cubic centimeters	cu. inches	0.06102
Cubic centimeters	gallons (U.S. liq.)	2.642 x 10 ⁻⁴
Cubic feet	cu. cms.	28,320.0
Cubic feet	cu. inches	1,728.0
Cubic feet	gallons (U.S. liq.)	7.481
Cubic feet	liters	28.32
Cubic feet/hour	cubic meters/hour	0.02832
Cubic feet/min.	gallons/sec.	0.1247
Cubic feet/min.	cubic meters/hour	1.6990
Cubic inches	cu. cms.	16.39
Cubic inches	gallons	4.329 x 10 ⁻³
Cubic inches	quarts (U.S. liq.)	0.01732
Cubic meters	cu. feet	35.31
Cubic meters	gallons (U.S. liq.)	264.2
Cubic meters/hour	cu. feet/min	0.5886
Cubic meters/hour	cu. feet/hour	35.315
Cubic meters/hour	gallons /hour	264.17

D

Degres (angle)	radians	0.01745
Drams	ounces (avoidupois)	0.13714
Drams (apothecaries' or troy)	ounces (troy)	0.125
Drams (U.S., fluid or apoth)	cubic cm.	3.6967
Drams	grams	1.772
Drams	grains	27.3437
Drams	ounces	0.0625

F

Fahrenheit	centigrade	(F 32°) 5/9
Feet	centimeters	30.48
Feet	kilometers	3.048 x 10 ⁻⁴
Feet	meters	0.3048
Feet	miles (naut.)	1.645 x 10 ⁻⁴
Feet	miles (stat.)	1.894 x 10 ⁻⁴
Feet of water	atmospheres	0.02950
Feet of water	in. of mercury	0.8826
Feet of water	kgs./sq. cm.	0.03045
Feet of water	kgs./sq. meter	304.8
Feet of water	pounds/sq.ft.	62.43
Feet of water	pounds/sq.in	0.4335
Foot-pounds	Btu	1.286 x 10 ⁻³

To Convert Into Multipli by

Foot-pounds	gram-calories	0.3238
Foot-pounds	hp.-hrs.	5.050 x 10 ⁻⁷
Foot-pounds	kilowatt-hrs.	3.766 x 10 ⁻⁷
Foot-pounds/min.	Btu/min.	1.286 x 10 ⁻³
Foot-pounds/min.	horsepower	3.030 x 10 ⁻⁵
Foot-pounds/sec.	Btu/hr.	4.6263
Furlongs	miles (U.S.)	0.125
Furlongs	feet	660.0

G

Gallons	cu.cms	3.785.0
Gallons	cu.feet	0.1337
Gallons	cu.inches	231.0
Gallons	cu.meters	3.785 x 10 ⁻³
Gallons	cu.yards	4.951 x 10 ⁻³
Gallons	liters	3.785
Gallons (liq. Br Imp.)	gallons (U.S. liq.)	1.20095
Gallons (U.S.)	gallons (Imp.)	0.83267
Gallons of water	pounds of water	8.3453
Gallons/min.	cu.ft./sec.	2.228 x 10 ⁻³
Gallons/min.	liters/sec.	0.06308
Gallons/min.	cu.ft./hr.	8.0208
Grains (troy)	grain (avdp.)	1.0
Grains (troy)	grams	0.06480
Grains (troy)	ounces (avdp.)	2.286 x 10 ⁻³
Grains (troy)	pennyweight (troy)	0.04167
Grains /U.S. gal.	parts/million	17.118
Grains /U.S. gal.	pounds/million gal.	142.86
Grains /Imp. gal.	parts/million	14.286
Grams	grains	15.43
Grams	ounces (avdp.)	0.03527
Grams	ounces (troy)	0.03215
Grams	poundals	0.07093
Grams	pounds	2.205 x 10 ⁻³
Gram/liter	parts/million	1.000.0
Gram-calories	Btu	3.9683 x 10 ⁻³
Gram-calories	foot-pounds	3.0880
Gram-calories	kilowatt-hrs.	1.1630 x 10 ⁻⁶
Gram-calories	watt-hrs.	1.1630 x 10 ⁻³

H

Horsepower	Btu/min.	42.40
Horsepower	foot-lbs./min.	33.000
Horsepower	foot-lbs./sec.	550.0
Horsepower (metric)	horsepower	0.9863
542.5 ft. lb/sec.)	(550.5 ft. lb/sec.)	
Horsepower (550.5 ft. lb/sec.)	horsepower (metric)	1.014
Horsepower	(542.5 ft. lb/sec.)	
Horsepower	kilowatts	0.7457
Horsepower	watts	745.7
Horsepower (boiler)	Btu/hr	33.520
Horsepower (boiler)	kilowatts	9.803
Horsepower-hrs.	Btu	2.547
Horsepower-hrs.	foot-lbs.	1.98 x 10 ⁶
Horsepower-hrs.	kilowatts-hrs.	0.7457

I

Inches	centimeters	2.540
Inches	meters	2.540 x 10 ⁻²
Inches	millimeters	25.40
Inches	yards	2.778 x 10 ⁻²
Inches of mercury	atmospheres	0.03342
Inches of mercury	feet of water	1.133
Inches of mercury	kgs./sq. cm.	0.03453
Inches of mercury	kgs./sq. meter	345.3
Inches of mercury	pounds/sq. ft.	70.73
Inches of mercury	pounds/sq. in.	0.4912
Inches of water (at 4°C)	atmospheres	2.458 x 10 ⁻³
Inches of water (at 4°C)	inches of mercury	0.07355
Inches of water (at 4°C)	kgs./sq. cm.	2.538 x 10 ⁻³
Inches of water (at 4°C)	ounces/sq. in.	0.5781
Inches of water (at 4°C)	pounds/sq. ft.	5.204
Inches of water (at 4°C)	pounds/sq. in.	0.03613

J

Joules	Btu	9.480 x 10 ⁻⁴
--------	-----	--------------------------



Conversion Tables

To Convert	Into	Multipl by
K		
Kilograms	grams	1,000.0
Kilograms	pounds	2.205
Kilograms/cu. meter	pounds/cu. ft.	0.06243
Kilograms/cu. meter	pounds/cu. in.	3.613 x 10 ⁻⁵
Kilograms/sq. cm	atmosphere	0.9678
Kilograms/sq. cm	feet of water	32.84
Kilograms/sq. cm	inches of mercury	28.96
Kilograms/sq. cm.	pounds/sq. ft.	2,048
Kilograms/sq. cm.	pounds/sq. in.	14.22
Kilograms/sq. meter	atmosphere	9.678 x 10 ⁻⁵
Kilograms/sq. meter	feet of water	3.281 x 10 ⁻³
Kilograms/sq. meter	inches of mercury	2.896 x 10 ⁻³
Kilograms/sq. meter	pounds/sq. ft.	0.2048
Kilograms/sq. meter	pounds/sq. in.	1.422 x 10 ⁻³
Kilograms/sq. mm.	kgs./sq. meter	106
Kilograms-calories	Btu	3.968
Kilograms-calories	foot-pounds	3.088
Kilograms-calories	hp-hrs	1.560 x 10 ⁻³
Kilograms-calories	kilowatt-hrs	1.163 x 10 ⁻³
Kilograms meters	Btu	9.294 x 10 ⁻³
Kilometers	centimeters	105
Kilometers	feet	3.281
Kilometers	miles	0.6214
kilowatts	Btu/min.	56.87
kilowatts	foot-lbs./min.	4.426 x 10 ⁴
kilopascal	Bar	0.01
kilopascal	Pounds/sq.in	0.145
kilowatts	horsepower	1.341
kilowatts-hrs.	Btu	3.413
kilowatts-hrs.	foot-lbs.	2.655 x 10 ⁶
kilowatts-hrs.	horsepower-hrs.	1.341
knots	statute miles/hr.	1.151

To Convert	Into	Multipl by
L		
Liters	cu. cm.	1,000.0
Liters	cu. feet	0.03531
Liters	cu. inches	61.02
Liters	gallons (U.S. liq.)	0.2642

To Convert	Into	Multipl by
M		
Meters	centimeters	100.0
Meters	feet	3.281
Meters	inches	39.37
Meters	millimeters	1,000.0
Meters	yards	1.094
Microns	inches	39.37 x 10 ⁻⁶
Microns	meters	1 x 10 ⁻⁶
Miles (statute)	feet	5,280
Miles (statute)	kilometers	1.609
Miles/hr.	cms./sec.	44.70
Miles/hr.	feet/min.	88.
Mils	inches	0.001
Mils	yards	2.778 x 10 ⁻⁵

To Convert	Into	Multipl by
N		
Nepers	decibels	8.686

To Convert	Into	Multipl by
O		
Ohms	megohms	10 ⁻⁶
Ohms	microhms	10 ⁶
Ounces (avoirdupois)	drams	16.0
Ounces (avoirdupois)	grains	437.5
Ounces (avoirdupois)	grams	28.35
Ounces (avoirdupois)	pounds	0.0625
Ounces (avoirdupois)	ounces (troy)	0.9115
Ounces (troy)	grains	480.0
Ounces (troy)	grams	31.10
Ounces (troy)	ounces (avdp.)	1.09714
Ounces (troy)	pounds (troy)	0.08333

To Convert	Into	Multipl by
P		
Pound/sq in.	bar	0.06894
Pound/sq in.	pascal	6894.14
Pound/sq in.	pounds/sq foot	144
Pascal (N/m ²)	bar	10 ⁻⁵
Pascal (N/m ²)	pound/sq in.	0.145 x 10 ⁻³
Pascal (N/m ²)	atmosphere	1.0197 x 10 ⁻⁵
Pounds (avoirdupois)	ounces (troy)	14.58
Pounds (avoirdupois)	drams	256.

To Convert	Into	Multipl by
P		
Pounds (avoirdupois)	grains	7,000
Pounds (avoirdupois)	grams	28.35
Pounds (avoirdupois)	kilograms	0.02835
Pounds (avoirdupois)	ounces	16.0
Pounds (troy)	ounces (avdp.)	13.1657
Pounds of water	cu. feet	0.01602
Pounds of water	cu. inches	27.68
Pounds of water	gallons	0.1198
Pounds of water/min.	cu. ft./sec.	2.670 x 10 ⁻⁴
Pounds/cu. ft.	grams/cu. cm.	0.01602
Pounds/cu. ft.	kgs./cu. meter	16.02
Pounds/cu. ft.	pounds/cu. in.	5.787 x 10 ⁻⁴
Pounds/cu. in.	pounds/cu. ft.	1.728
Pounds/cu. in.	atmospheres	4.725 x 10 ⁻⁴
Pounds/sq. ft.	feet of water	0.01602
Pounds/sq. ft.	inches of mercury	0.014414
Pounds/sq. in.	atmospheres	0.06804
Pounds/sq. in.	feet of water	2.307
Pounds/sq. in.	inches of mercury	2.036
Pounds/sq. in.	kgs./sq. meter	703.1
Pounds/sq. in.	pounds/sq. ft.	144.0

To Convert	Into	Multipl by
R		
Radians	degrees	57.30
Revolution/min.	degrees/sec.	6.0
Revolution/min.	radians/sec.	0.1047
Revolution/min.	rev./sec.	0.01667

To Convert	Into	Multipl by
S		
Square centimeters	sq. feet	1.076 x 10 ⁻³
Square centimeters	sq. inches	0.1550
Square centimeters	sq. meters	0.0001
Square centimeters	sq. millimeters	100.0
Square feet	acres	2.296 x 10 ⁻⁵
Square feet	sq. cms.	929.0
Square feet	sq. inches	144.0
Square feet	sq. miles	3.587 x 10 ⁻⁸
Square feet	sq. cms.	6.452
Square inches	sq. feet	6.944 x 10 ⁻³
Square inches	sq. yards	7.716 x 10 ⁻⁴
Square inches	sq. feet	10.76
Square meters	sq. inches	1.550
Square meters	sq. millimeters	106
Square meters	sq. yards	1.196
Square millimeters	sq. inches	1.550 x 10 ⁻³
Square yards	sq. feet	9.0
Square yards	sq. inches	1.296
Square yards	sq. meters	0.8361

To Convert	Into	Multipl by
T		
Temperature (°C) + 273	absolute temperature (°C)	1.0
Temperature (°C) + 17.78	temperature (°F)	1.8
Temperature (°F) + 460	absolute temperature (°F)	1.0
Temperature (°F) - 32°	temperature (°C)	5/9
Tons (long)	kilograms	1,016
Tons (long)	pounds	2,240.
Tons (long)	ton (short)	1.120
Tons (metric)	kilograms	1,000
Tons (metric)	pounds	2,205.
Tons (short)	kilograms	907.2
Tons (short)	pounds	2,000
Tons (short)	ton (long)	0.89287
Tons of water/24hrs	pounds of water	83,333
Tons of water/24hrs	gallons/min.	0.16643
Tons of water/24hrs	cu. ft./hr.	1.3349

To Convert	Into	Multipl by
W		
Watts	Btu/hr.	3.4129
Watts	Btu/min.	0.05688
Watts	horsepower	1.341 x 10 ⁻³
Watts	horsepower (metric)	1.360 x 10 ⁻³
Watts	kilowatts	0.001
Watts	B.T.U. (mean)/min.	0.056884
Watts	Btu	3.413
Watts	horsepower-hrs.	1.341 x 10 ⁻³

To Convert	Into	Multipl by
Y		
Yards	centimeters	91.44
Yards	kilometers	9.144 x10 ⁻⁴
Yards	meters	0.9144



Temperature Conversion Table

$$^{\circ}\text{C} = \frac{5}{9} (^{\circ}\text{F} - 32)$$

$$^{\circ}\text{F} = \frac{9}{5} ^{\circ}\text{C} + 32$$

$^{\circ}\text{C}$		$^{\circ}\text{F}$	$^{\circ}\text{C}$		$^{\circ}\text{F}$
-273.0	-459.4		43.3	110	230.0
-268.0	-450		46.1	115	239.0
-240.0	-400		48.9	120	248.0
-212.0	-350		54.4	130	266.0
-184.0	-300		60.0	140	284.0
-157.0	-250	-418.0	65.6	150	302.0
-129.0	-200	-328.0	71.1	160	320.0
-101.0	-150	-238.0	76.7	170	338.0
- 73.0	-100	-148.0	82.2	180	356.0
- 45.6	- 50	- 58.0	87.8	190	374.0
- 42.8	- 45	- 49.0	93.3	200	392.0
- 40.0	- 40	- 40.0	98.9	210	410.0
- 37.2	- 35	- 31.0	104.4	220	428.0
- 34.4	- 30	22.0	110.0	230	446.0
- 31.7	- 25	- 13.0	115.6	240	464.0
- 28.9	- 20	- 4.0	121.0	250	482.0
- 26.1	- 15	5.0	149.0	300	572.0
- 23.2	- 10	14.0	177.0	350	662.0
- 20.6	- 5	23.0	204.0	400	752.0
- 17.8	0	32.0	232.0	450	842.0
- 15.0	5	41.0	260.0	500	932.0
- 12.2	10	50.0	288.0	550	1022.0
- 9.4	15	59.0	316.0	600	1112.0
- 6.7	20	68.0	343.0	650	1202.0
- 3.9	25	77.0	371.0	700	1292.0
- 1.1	30	86.0	399.0	750	1382.0
0	32	89.6	427.0	800	1472.0
7.7	35	95.0	454.0	850	1562.0
4.4	40	104.0	482.0	900	1652.0
7.2	45	113.0	510.0	950	1742.0
10.0	50	122.0	538.0	1000	1832.0
12.8	55	131.0	566.0	1050	1922.0
15.6	60	140.0	593.0	1100	2012.0
18.3	65	149.0	621.0	1150	2102.0
21.1	70	158.0	649.0	1200	2192.0
23.9	75	167.0	677.0	1250	2282.0
26.7	80	176.0	704.0	1300	2372.0
29.4	85	185.0	732.0	1350	2462.0
32.2	90	194.0	762.0	1400	2552.0
35.0	95	203.0	788.0	1450	2642.0
37.8	100	212.0	816.0	1500	2732.0
40.6	105	221.0			

NOTES: The temperature to be converted is the figure in the yellow column.
To obtain a reading in $^{\circ}\text{C}$ use left column; for conversion to $^{\circ}\text{F}$ use the right column.



Pressure/Temperature Rating According to ASME B16.34-2013

Material: ASTM A 105, ASTM A 216 Gr. WCB, ASTM A 350 Gr. LF2 (Table 2-1.1)

Temperature	Working Pressures by Classes, psig (Bar)					
°F (°C)	150	300	600	900	1500	2500
-20 to 10 (-29 to 38)	285 (20)	740 (51)	1.480 (102)	2.220 (153)	3.705 (255)	6.170 (425)
200 (93)	260 (18)	680 (47)	1.360 (94)	2.035 (140)	3.395 (234)	5.655 (390)
300 (149)	230 (16)	655 (45)	1.310 (90)	1.965 (135)	3.270 (225)	5.450 (376)
400 (204)	200 (14)	635 (44)	1.265 (87)	1.900 (131)	3.170 (219)	5.280 (364)
500 (260)	170 (12)	605 (42)	1.205 (83)	1.810 (125)	3.015 (208)	5.025 (346)
600 (316)	140 (10)	570 (39)	1.135 (78)	1.705 (118)	2.840 (196)	4.730 (326)
650 (343)	125 (9)	550 (38)	1.100 (76)	1.650 (114)	2.745 (189)	4.575 (315)
700 (371)	110 (8)	530 (36)	1.060 (73)	1.590 (110)	2.665 (184)	4.425 (305)

Material: ASTM A 216 Gr. WCC, ASTM A 352 Gr. LCC/LC2/LC3 (Table 2-1.2)

Temperature	Working Pressures by Classes, psig (Bar)					
°F (°C)	150	300	600	900	1500	2500
-20 to 10 (-29 to 38)	290 (20)	750 (52)	1.500 (103)	2.250 (155)	3.750 (259)	6.250 (431)
200 (93)	260 (18)	750 (52)	1.500 (103)	2.250 (155)	3.750 (259)	6.250 (431)
300 (149)	230 (16)	730 (50)	1.455 (100)	2.185 (151)	3.640 (251)	6.070 (419)
400 (204)	200 (14)	705 (49)	1.405 (97)	2.110 (145)	3.520 (243)	5.865 (404)
500 (260)	170 (12)	665 (46)	1.330 (92)	1.995 (137)	3.325 (229)	5.540 (382)
600 (316)	140 (10)	605 (42)	1.210 (83)	1.815 (125)	3.025 (209)	5.040 (348)
650 (343)	125 (9)	590 (41)	1.175 (81)	1.765 (122)	2.940 (203)	4.905 (338)
700 (371)	110 (8)	555 (38)	1.110 (76)	1.665 (115)	2.775 (191)	4.630 (319)

Material: ASTM A 352 Gr. LCB (Table 2-1.3)

Temperature	Working Pressures by Classes, psig (Bar)					
°F (°C)	150	300	600	900	1500	2500
-20 to 10 (-29 to 38)	265 (18)	695 (48)	1.395 (96)	2.090 (144)	3.480 (240)	5.805 (400)
200 (93)	255 (17)	660 (45)	1.320 (91)	1.980 (136)	3.300 (227)	5.505 (379)
300 (149)	230 (16)	640 (44)	1.275 (88)	1.915 (132)	3.190 (220)	5.315 (366)
400 (204)	200 (14)	615 (42)	1.230 (85)	1.845 (127)	3.075 (212)	5.125 (353)
500 (260)	170 (12)	585 (40)	1.175 (81)	1.760 (121)	2.930 (202)	4.885 (337)
600 (316)	140 (10)	550 (38)	1.105 (76)	1.655 (114)	2.755 (190)	4.595 (317)
650 (343)	125 (9)	535 (37)	1.065 (73)	1.600 (110)	2.665 (184)	4.440 (306)
700 (371)	110 (8)	510 (35)	1.025 (71)	1.535 (106)	2.560 (176)	4.270 (294)

Material: ASTM A 182 Gr. F316/F316H, ASTM A 479 Gr. 316/316H, ASTM A 351Gr. CF3M/CF8M (Table 2-2.2)

Temperature	Working Pressures by Classes, psig (Bar)					
°F (°C)	150	300	600	900	1500	2500
-20 to 10 (-29 to 38)	275 (19)	720 (50)	1.440 (99)	2.160 (149)	3.600 (248)	6.000 (414)
200 (93)	235 (16)	620 (43)	1.240 (85)	1.860 (128)	3.095 (213)	5.160 (356)
300 (149)	215 (15)	560 (39)	1.120 (77)	1.680 (116)	2.795 (193)	4.660 (321)
400 (204)	195 (13)	515 (36)	1.025 (71)	1.540 (106)	2.570 (177)	4.280 (295)
500 (260)	170 (12)	480 (33)	955 (66)	1.435 (99)	2.390 (165)	3.980 (274)
600 (316)	140 (10)	450 (31)	900 (62)	1.355 (93)	2.255 (155)	3.760 (259)
650 (343)	125 (9)	440 (30)	885 (61)	1.325 (91)	2.210 (152)	3.680 (254)
700 (371)	110 (8)	435 (30)	870 (60)	1.305 (90)	2.170 (150)	3.620 (250)



Chemical and Mechanical Requirements - Forged / bar

Composition % (Maximum Percent Unless Range is Given)									
	ASTM Standard (UNS designation)	Nominal Composition	C	Mn	P	S	Si		
Carbon Steel	A 105 (1) (2) (3)		0,35	0,60-1,05	0,035	0,040	0,10-0,35		
	A 350 LF1 (2) (3)		0,30	0,60-1,35	0,035	0,040	0,15-0,30		
	A 350 LF2 (2) (3)		0,30	0,60-1,35	0,035	0,040	0,15-0,30		
Low Alloy	A 350 LF3 (3)		0,20	0,90	0,035	0,040	0,20-0,35		
	A 29 Gr.4140		0,38-0,43	0,75-1,00	0,035	0,040	0,15-0,35		
	A 29 Gr.4340		0,38-0,43	0,60-0,80	0,035	0,040	0,15-0,35		
	A 182 F1	(UNS K12822)	C-Mo	0,28	0,60-0,90	0,045	0,045	0,15-0,35	
	A 182 F2	(UNS K12122)	0,5Cr-0,5Mo	0,05-0,21	0,30-0,80	0,040	0,040	0,10-0,60	
	A 182 F5a	(UNS K42544)	5Cr	0,25	0,60	0,040	0,030	0,50	
	A 182 F9	(UNS K90941)	9Cr	0,15	0,30-0,60	0,030	0,030	0,50-1,00	
	A 182 F11 CL.3	(UNS K11572)	1,25Cr-0,5Mo	0,10-0,20	0,30-0,80	0,040	0,040	0,50-1,00	
	A 182 F12 CL.2	(UNS K11564)	1Cr-0,5Mo	0,10-0,20	0,30-0,80	0,040	0,040	0,10-0,60	
	A 182 F22 CL.3	(UNS K21590)	Cr-Mo	0,05-0,15	0,30-0,60	0,040	0,040	0,50	
	Martensitic	A182 F6a CL.2	(UNS S41000)	13Cr	0,15	1,00	0,040	0,030	1,00
A 182 F6NM		(UNS S41500)	13Cr-4Ni	0,05	0,5-1,0	0,030	0,030	0,60	
Austenitic Stainless Steel	A 182 F304 (4)	(UNS S30400)	18Cr-8Ni	0,08	2,00	0,045	0,030	1,00	
	A 182 F304H (4)	(UNS S30409)	18Cr-8Ni	0,04-0,10	2,00	0,045	0,030	1,00	
	A 182 F304L (4)	(UNS S30403)	18Cr-8Ni	0,035	2,00	0,045	0,030	1,00	
	A 182 F316 (4)	(UNS S31600)	18Cr-10Ni-Mo	0,08	2,00	0,045	0,030	1,00	
	A 182 F316H (4)	(UNS S31609)	18Cr-10Ni-Mo	0,04-0,10	2,00	0,045	0,030	1,00	
	A 182 F316L (4)	(UNS S31603)	18Cr-10Ni-Mo	0,030	2,00	0,045	0,030	1,00	
	A 182 F310	(UNS S31000)	25Cr-20Ni	0,25	2,00	0,045	0,030	1,00	
	A 182 F44	(UNS S31254)	20Cr-18Ni-6Mo	0,020	1,00	0,030	0,010	0,80	
	B 462- UNS N08020	(ALLOY 20)	29Ni-20Ni-3Cu-2Mo	0,07	2,00	0,045	0,035	1,00	
Austenitic Ferritic Stainless Steel	A 182 F51	(UNS S31803)	22Cr-5Ni	0,030	2,00	0,030	0,020	1,00	
	A 182 F53	(UNS S32750)	25Cr-7Ni-4Mo	0,030	1,20	0,035	0,020	0,80	
	A 182 F55	(UNS S32760) (5)	25Cr-7Ni-3,5Mo	0,030	1,00	0,030	0,010	1,00	
Age hardened SS	A 564 Gr 630 H900	(UNS S17400)	16Cr-4Ni-4Cu	0,07	1,00	0,040	0,030	1,00	
	A 564 Gr 630 H1150M	(UNS S17400)	16Cr-4Ni-4Cu	0,07	1,00	0,040	0,030	1,00	
Titanium	B 348 Gr.3	(Unalloyed Titanium)	Ti	0,08	Ti=Balance	H=0,015	Fe=0,30	O=0,35	
	B 348 Gr.5	(Titanium Alloy)	6Al-4V	0,08	Ti=Balance	H=0,015	Fe=0,40	O=0,20	
Nickel Alloy	B 564-UNS N06625	(INCONEL 625)	60Ni-22Cr-9Mo-3,5Cb	0,10	0,5	0,015	0,015	0,5	
	B 564-UNS N08825	(INCONEL 825)		0,05	1,0		0,03	0,5	

- (1) For each reduction of 0,01% below the specified maximum carbon content, an increase of 0,06% Mn above the specified maximum will be permitted up to a maximum of 1,35%.
- (2) $Cu + Ni + Cr + Mo \leq 1,00\%$



Materials for Body, Plug, Cover and Stem Components

						Mechanical Properties			
Cr	Mo	Ni	Cu	V	Others Elements	Tensile Strength min, ksi (MPa)	Yield Strength min, ksi (MPa)	Elongation min%	Reduction of area min%
0,30	0,12	0,40	0,40	0,08	Cb = 0,02	70 (485)	36 (250)	22	30
0,30	0,12	0,40	0,40	0,08	Cb=0,02	60 (415)	30 (205)	25	38
0,30	0,12	0,40	0,40	0,08	Cb=0,02	70 (485)	36 (250)	22	30
0,30	0,12	3,3-3,7	0,40	0,03	Cb=0,02	70 (485)	37,5 (260)	22	35
0,80-1,10	0,15-0,25	-	-	-	-	100 (690)	75 (520)	20	50
0,70-0,90	0,20-0,30	1,65-2,00	-	-	-	115 (790)	96 (660)	16	45
-	0,44-0,65	-	-	-	-	70 (485)	40 (275)	20	30
0,50-0,81	0,44-0,65	-	-	-	-	70 (485)	40 (275)	20	30
4,0-6,0	0,44-0,65	0,50	-	-	-	90 (620)	65 (450)	22	50
8,0-10,0	0,90-1,10	-	-	-	-	85 (585)	55 (380)	20	40
1,00-1,50	0,44-0,65	-	-	-	-	75 (515)	45 (310)	20	30
0,80-1,25	0,44-0,65	-	-	-	-	70 (485)	40 (275)	20	30
2,00-2,50	0,87-1,13	-	-	-	-	75 (515)	45 (310)	20	30
11,5-13,5	-	0,50	-	-	-	85 (585)	55 (380)	18	35
11,5-14,0	0,5-1,0	3,5-5,5	-	-	-	115 (790)	90 (620)	15	45
18,0-20,0	-	8,0-11,0	-	-	-	75 (515)	30 (205)	30	50
18,0-20,0	-	8,0-11,0	-	-	-	75 (515)	30 (205)	30	50
18,0-20,0	-	8,0-13,0	-	-	-	70 (485)	25 (170)	30	50
16,0-18,0	2,00-3,00	10,0-14,0	-	-	-	75 (515)	30 (205)	30	50
16,0-18,0	2,00-3,00	10,0-14,0	-	-	-	75 (515)	30 (205)	30	50
16,0-18,0	2,00-3,00	10,0-15,0	-	-	-	70 (485)	25 (170)	30	50
19,0-22,0	-	24,0-26,0	-	-	-	75 (515)	30 (205)	30	50
19,5-20,5	6,0-6,5	17,5-18,5	0,5-1,0	-	N=0,18-0,22	94 (650)	44 (300)	35	50
19,00-21,00	2,00-3,00	32,00-38,00	3,00-4,00	-	-	80 (551)	35 (241)	30	50
21,0-23,0	2,5-3,5	4,5-6,5	-	-	N=0,08-0,20	90 (620)	65 (450)	25	45
24,0-26,0	3,0-5,0	6,0-8,0	0,5	-	N=0,24-0,32	116 (800)	80 (550)	15	-
24,0-26,0	3,0-4,0	6,0-8,0	0,50-1,00	N=0,20-0,30	W=0,50-1,00	109 (750)	80 (550)	25	45
15,0-17,5	-	3,00-5,00	3,00-5,00	-	-	190 (1.310)	170 (1.170)	10	40
15,0-17,5	-	3,00-5,00	3,00-5,00	-	-	115 (795)	75 (515)	18	55
-	-	-	-	-	N=0,05	65 (450)	55 (380)	18	30
Al=5,5-6,75	-	-	-	3,5-4,5	N=0,05	130 (895)	120 (828)	10	25
20,0-23,0	8,0-10,0	58,0Min	Ta+Cb=3,15-4,15	Ti=0,4	Fe=5,0Al=0,4	110 (758)	50 (345)	25	-
19,5-23,5	2,5-3,5	38,0-46,0	1,5-3,0	Ti=0,6-1,2	Fe=22,0Al=0,2	85 (586)	35 (241)	30	-

(3) $Cr + Mo \leq 0,32\%$

(4) Maximum nitrogen content of 0,10%

(5) Pitting Resistance Equivalent Number (PREN) = $Cr + 3,3Mo + 16N \leq 40$.



Chemical and Mechanical Requirements - Cast Materials

Composition % (Maximum Percent Unless Range is Given)							
	ASTM Standard (UNS designation)	Nominal Composition	C	Mn	P	S	Si
Carbon Steel	A 216 WCB (2)		0,30	1,00	0,035	0,035	0,60
	A 216 WCC (2)		0,25	1,20	0,035	0,035	0,60
	A 352 LCB (UNS J03003) (2)		0,30	1,00	0,040	0,045	0,60
	A 352 LCC (UNS J02505) (2)		0,25	1,20	0,040	0,045	0,60
	A 352 LC3 (UNS J31550)	3,5Ni	0,15	0,50-0,80	0,040	0,045	0,60
	A 487 Gr4Q 4-C	Ni-Cr-Mo	0,030	1,00	0,040	0,045	0,80
Low Alloy	A 217 WC1	C-Mo	0,25	0,50-0,80	0,040	0,045	0,60
	A 217 WC6	Cr-Mo	0,05-0,20	0,50-0,80	0,035	0,035	0,60
	A 217 WC9	Cr-Mo	0,05-0,18	0,40-0,70	0,035	0,035	0,60
	A 217 C5	Cr-Mo	0,20	0,40-0,70	0,040	0,045	0,75
	A 217 C12	Cr-Mo	0,20	0,35-0,65	0,035	0,035	1,00
Martensitic	A 217 CA15 (UNS J91150)	13Cr	0,15	1,00	0,040	0,025	1,50
	A 487 CA6NM (UNS J91540)	13Cr-4Ni	0,06	1,00	0,040	0,030	1,00
Austenitic Stainless Steel	A 351 CF3 (UNS J92500)	18Cr-8Ni	0,03	1,50	0,040	0,040	2,00
	A 351 CF3M (UNS J92800)	16Cr-12Ni-2Mo	0,03	1,50	0,040	0,040	1,50
	A 351 CF8 (UNS J92600)	18Cr-8Ni	0,08	1,50	0,040	0,040	2,00
	A 351 CF8C (UNS 92710) (1)	18Cr-10Ni-2Co	0,08	1,50	0,040	0,040	2,00
	A 351 CF8M (UNS J92900)	16Cr-12Ni-2Mo	0,08	1,50	0,040	0,040	1,50
	A 351 CN7M (UNS N08007)	29Ni-20Cr-3Cu-2Mo	0,07	1,50	0,040	0,040	1,50
	A 351 CK3MCuN (UNS J93254) (3)	20Cr-18Ni-6Mo-N	0,025	1,20	0,045	0,010	1,00
Cast Austenitic Ferritic (Duplex) Stainless Steel	A 890 CD3MN (UNS J92205)	22Cr-5Ni-Mo-N	0,03	1,50	0,040	0,020	1,00
	A 890 CE3MN (UNS J93404) (3)	25Cr-7Ni-Mo-N	0,03	1,50	0,040	0,040	1,00
	A 890 CD3MWCuN (UNS J93380)(3)	25Cr-7Ni-Mo-N	0,03	1,00	0,030	0,025	1,00

Chemical and Mechanical Requirements Bolting Materials

Stud	A 193 B7 and B7M (5)	Cr-Mo	0,38-0,48	0,75-1,00	0,035	0,040	0,15-0,35
	A 193 B16	Cr-Mo-V	0,36-0,47	0,45-0,70	0,035	0,040	0,15-0,35
	A 193 B8M CL.2	18Cr-10Ni-2Mo	0,08	2,00	0,045	0,030	1,00
	A 320 L43	Ni-Cr-Mo	0,38-0,43	0,60-0,85	0,035	0,040	0,15-0,35
	A 320 L7 and L7M (5)	Cr-Mo	0,38-0,48	0,75-1,00	0,035	0,040	0,15-0,35
	A 453 Gr 660A		0,08	2,00	0,040	0,030	1,00
Nut	A 194 2H/2HM	C	min 0,40	1,00	0,040	0,050	0,40
	A 194 4	C-Mo	0,40-0,50	0,70-0,90	0,035	0,040	0,15-0,35
	A 194 7/7M	Cr-Mo	0,38-0,48	0,75-1,00	0,035	0,040	0,15-0,35
	A 194 8M	18Cr-10Ni-2Mo	0,08	2,00	0,045	0,030	1,00

- (1) Grade CF8C shall have a columbium content of not less than 8 times the carbon content but not over 1,00%
 (2) For each reduction of 0,01% below the specified maximum carbon content, and increase of 0,04% Mn above the specified maximum will be permitted up to a maximum of: 1,28% for WCB and LCB; 1,40% for WCC and LCC.



for Body, Plug and Cover Components

Mechanical Properties

Cr	Mo	Ni	Cu	V	W	Tensile Strength min, ksi (MPa)	Yield Strength min, ksi (MPa)	Elongation min%	Reduction of area min%
0,50	0,20	0,50	0,30	0,03	-	70 (485)	36 (250)	22	35
0,50	0,20	0,50	0,30	0,03	-	70 (485)	40 (275)	22	35
0,50	0,20	0,50	0,30	0,03	-	65 (450)	35 (240)	24	35
0,50	0,20	0,50	-	0,03	-	70 (485)	40 (275)	22	35
	-	3,00-4,00	-	-	-	70 (485)	40 (275)	24	35
0,40-0,80	0,15-0,30	0,4-0,80	0,50	0,03	0,10	90 (620)	60 (415)	18	35
0,35	0,45-0,65	-	0,50	-	0,10	65 (450)	35 (240)	24	35
1,00-1,50	0,45-0,65	0,50	0,50	-	0,10	70 (485)	40 (275)	20	35
2,00-2,75	0,90-1,20	0,50	0,50	-	0,10	70 (485)	40 (275)	20	35
4,00-6,50	0,45-0,65	0,50	0,50	-	0,10	90 (620)	60 (415)	18	35
8,00-10,00	0,90-1,20	0,50	0,50	-	0,10	90 (620)	60 (415)	18	35
11,50-14,00	0,50	1,00	-	-	-	90 (620)	65 (450)	18	30
11,5-14,0	0,4-1,0	3,5-4,5	0,50	0,05	0,10	100 (690)	75 (515)	17	35
17,00-21,00	0,50	8,00-12,00	-	-	-	70 (485)	30 (206)	35	-
17,00-21,00	2,00-3,00	9,00-13,00	-	-	-	70 (485)	30 (206)	30	-
18,00-21,00	0,50	8,00-11,00	-	-	-	70 (485)	30 (206)	35	-
18,00-21,00	0,50	9,00-12,00	-	-	-	70 (485)	30 (206)	30	-
18,00-21,00	2,00-3,00	9,00-12,00	-	-	-	70 (485)	30 (206)	30	-
19,0-22,0	2,0-3,0	27,5-30,5	3,0-4,0	-	-	62 (425)	25 (170)	35	-
19,5-20,5	6,0-7,0	17,5-19,5	0,50-1,00	-	N=0,18-0,24	80 (550)	38 (260)	35	-
21,0-23,5	2,5-3,5	4,5-6,5	1,00	-	N=0,10-0,30	90 (620)	60 (415)	25	-
24,0-26,0	4,0-5,0	6,0-8,0	-	-	N=0,10-0,30	100 (690)	75 (515)	18	-
24,0-26,0	3,0-4,0	6,5-8,5	0,5-1,0	-	N=0,20-0,30	100 (690)	65 (450)	25	-

(Body / Plug)

0,75-1,20	0,15-0,25	-	-	-	-	125/100 (860/690)	105/80 (720/550)	16/18	50
0,80-1,15	0,50-0,65	-	-	0,25-0,35	Al=0,015	125 (860)	105 (725)	18	50
16,0-18,0	2,00-3,00	10,0-14,0	-	-	-	110 (760)	95 (655)	15	45
0,70-0,90	0,20-0,30	1,65-2,00	-	-	-	125 (860)	105 (725)	16	50
0,80-1,10	0,15-0,25	-	-	-	-	125/100 (860/690)	105/80 (725/550)	16/18	50
13,5-16,0	1,00-1,50	24,0-27,0	-	0,10-0,50	B=0,001-0,01 Ti=1,90-2,35	130 (895)	85 (585)	15	18
-	-	-	-	-	-	--	--	-	-
-	0,20-0,30	-	-	-	-	--	--	-	-
0,8-1,10	0,15-0,25	-	-	-	-	--	--	-	-
16,0-18,0	2,00-3,00	10,0-14,0	-	-	-	--	--	-	-

(3) Pitting Resistance Equivalent Number (PREN) = Cr + 3,3Mo + 16N ≤ 40.

(4) For 3/4" (M20) and under: 110/(760), 95/(655) 15; over 3/4" (M20) up to 1" (M24): 100/(690), 80/(550), 20 over 1" M24 up to 1.25" (M30) 95/(655), 65/(450), 25 over 1.25" (M30) up to 1.5" (M36): 90/(620), 50/(345), 30.

(5) For B7M and L7M grades, a minimum carbon content of 0,28% is permitted, provided that the required tensile properties are met in the section size involved.



Plug Valve Dimensions According to API Std. 6D/ISO14313

Face to Face (A) and End to End (B - C) dimensions in mm.

NPS (DN)	Short Welding End			Reduced (Regular) Welding End			Venturi Welding End			Round-Port, Full Bore Ring Joint		
	Raised Face	Welding End	Ring Joint	Raised Face	Welding End	Ring Joint	Raised Face	Welding End	Ring Joint	Raised Face	Welding End	Ring Joint
1 Inch/mm	2 A	3 B	4 C	5 A	6 B	7 C	8 A	9 B	10 C	11 A	12 B	13 C
CLASS 150 (PN 20)												
2 (50)	178	267	191	-	-	-	-	-	-	267	-	279
2 1/2 (65)	191	305	203	-	-	-	-	-	-	298	-	311
3 (80)	203	330	216	-	-	-	-	-	-	343	-	356
4 (100)	229	356	241	-	-	-	-	-	-	432	-	445
6 (150)	267	457	279	394	-	406	-	-	-	546	-	559
8 (200)	292	521	305	457	-	470	-	-	-	622	-	635
10 (250)	330	559	343	533	-	546	533	559	546	660	-	673
12 (300)	356	635	368	610	-	622	610	635	622	762	-	775
14 (350)	-	-	-	-	-	-	686	686	699	-	-	-
16 (400)	-	-	-	-	-	-	762	762	775	-	-	-
18 (450)	-	-	-	-	-	-	864	864	876	-	-	-
20 (500)	-	-	-	-	-	-	914	914	927	-	-	-
24 (600)	-	-	-	-	-	-	1067	1067	1080	-	-	-
CLASS 300 (PN50)												
2 (50)	216	267	232	-	-	-	-	-	-	283	283	298
2 1/2 (65)	241	305	257	-	-	-	-	-	-	330	330	346
3 (80)	283	330	298	-	-	-	-	-	-	387	387	403
4 (100)	305	356	321	-	-	-	-	-	-	457	457	473
6 (150)	403	457	419	403	-	419	403	457	419	559	559	575
8 (200)	419	521	435	502	-	518	419	521	435	686	686	702
10 (250)	457	559	473	568	-	584	457	559	473	826	826	841
12 (300)	502	635	518	-	-	-	502	635	518	965	965	981
14 (350)	-	-	-	-	-	-	762	762	778	-	-	-
16 (400)	-	-	-	-	-	-	838	838	854	-	-	-
18 (450)	-	-	-	914	-	930	914	914	930	-	-	-
20 (500)	-	-	-	991	-	1010	991	991	1010	-	-	-
22 (550)	-	-	-	1092	-	1114	1092	1092	1114	-	-	-
24 (600)	-	-	-	1143	-	1165	1143	1143	1165	-	-	-
26 (650)	-	-	-	1245	-	1270	1245	1245	1270	-	-	-
28 (700)	-	-	-	1346	-	1372	1346	1346	1372	-	-	-
30 (750)	-	-	-	1397	-	1422	1397	1397	1422	-	-	-
32 (800)	-	-	-	1524	-	1553	1524	1524	1553	-	-	-
34 (850)	-	-	-	1626	-	1654	1626	1626	1654	-	-	-
36 (900)	-	-	-	1727	-	1756	1727	1727	1756	-	-	-
CLASS 400 (PN 64)												
2 (50)	-	-	-	292	292	295	-	-	-	330	-	333
2 1/2 (65)	-	-	-	330	330	333	-	-	-	381	-	384
3 (80)	-	-	-	356	356	359	-	-	-	445	-	448
4 (100)	-	-	-	406	406	410	-	-	-	483	559	486
6 (200)	-	-	-	495	495	498	495	495	498	610	711	613
8 (200)	-	-	-	597	597	600	597	597	600	737	845	740
10 (250)	-	-	-	673	673	676	673	673	676	889	889	892
12 (300)	-	-	-	762	762	765	762	762	765	1016	1016	1019
14 (350)	-	-	-	-	-	-	826	826	829	-	-	-
16 (400)	-	-	-	-	-	-	902	902	905	-	-	-
18 (450)	-	-	-	-	-	-	978	978	981	-	-	-
20 (500)	-	-	-	-	-	-	1054	1054	1060	-	-	-
22 (550)	-	-	-	-	-	-	1143	1143	1153	-	-	-
24 (600)	-	-	-	-	-	-	1232	1232	1241	-	-	-
26 (650)	-	-	-	-	-	-	1308	1308	1321	-	-	-
28 (700)	-	-	-	-	-	-	1397	1397	1410	-	-	-
30 (750)	-	-	-	-	-	-	1524	1524	1537	-	-	-
32 (800)	-	-	-	-	-	-	1651	1651	1667	-	-	-
34 (850)	-	-	-	-	-	-	1778	1778	1794	-	-	-
36 (900)	-	-	-	-	-	-	1880	1880	1895	-	-	-

Tolerance: +/-2 mm. on sizes 10 in. (DN250) and smaller. +/-3 mm on sizes 12 in. (DN300) and larger.



Plug Valve Dimensions According to API Std. 6D/ISO14313

Face to Face (A) and End to End dimensions in mm.

NPS (DN)	Reduced (Regular)			Venturi			Round-Port , Full Bore		
	Raised Face	Welding End	Ring Joint	Raised Face	Welding End	Ring Joint	Raised Face	Welding End	Ring Joint
1 Inch/mm	2 A	3 B	4 C	5 A	6 B	7 C	8 A	9 B	10 C
CLASS 600 (PN 100)									
2 (50)	292	292	295	-	-	-	330	-	333
2½ (65)	330	330	333	-	-	-	381	-	384
3 (80)	356	356	359	-	-	-	445	-	448
4 (100)	432	432	435	-	-	-	508	559	511
6 (150)	559	559	562	559	559	562	660	711	664
8 (200)	660	660	664	660	660	664	794	845	797
10 (250)	787	787	791	787	787	791	940	1016	943
12 (300)	-	-	-	838	838	841	1067	1067	1070
14 (350)	-	-	-	889	889	892	-	-	-
16 (400)	-	-	-	991	991	994	-	-	-
18 (450)	-	-	-	1092	1092	1095	-	-	-
20 (500)	-	-	-	1194	1194	1200	-	-	-
22 (550)	-	-	-	1295	1295	1305	-	-	-
24 (600)	-	-	-	1397	1397	1407	-	-	-
26 (650)	-	-	-	1448	1448	1461	-	-	-
30 (750)	-	-	-	1651	1651	1664	-	-	-
32 (800)	-	-	-	1778	1778	1794	-	-	-
34 (850)	-	-	-	1930	1930	1946	-	-	-
36 (900)	-	-	-	2083	2083	2099	-	-	-
CLASS 900 (PN 150)									
2 (50)	368	-	371	-	-	-	381	-	384
2½ (65)	419	-	422	-	-	-	432	-	435
3 (80)	381	381	384	-	-	-	470	-	473
4 (100)	457	457	460	-	-	-	559	-	562
6 (150)	610	610	613	610	610	613	737	-	740
8 (200)	737	737	740	737	737	740	813	-	816
10 (250)	838	838	841	838	838	841	965	-	968
12 (300)	-	-	-	965	965	968	1118	-	1121
16 (400)	-	-	-	1130	1130	1140	-	-	-
CLASS 1500 (PN 250)									
2 (50)	368	-	371	-	-	-	391	-	394
2½ (65)	419	-	422	-	-	-	454	-	457
3 (80)	470	470	473	-	-	-	524	-	527
4 (100)	546	546	549	-	-	-	625	-	629
6 (150)	705	705	711	705	705	711	787	-	794
8 (200)	832	832	841	832	832	841	889	-	899
10 (250)	991	991	1000	991	991	1000	1067	-	1076
12 (300)	1130	1130	1146	1130	1130	1146	1219	-	1235
CLASS 2500 (PN 420)									
2 (50)	451	-	454	-	-	-	-	-	-
2½ (65)	508	-	514	-	-	-	-	-	-
3 (80)	578	-	584	-	-	-	-	-	-
4 (100)	673	-	683	-	-	-	-	-	-
6 (150)	914	-	927	-	-	-	-	-	-
8 (200)	1022	-	1038	-	-	-	-	-	-
10 (250)	1270	-	1292	-	-	-	-	-	-
12 (300)	1422	-	1445	-	-	-	-	-	-



Plug Valve Dimensions According to API Std. 6A/ISO 10423

Face to Face			
NPS (DN)	Reduced (Regular) Ring Joint	Round - Port, Full Bore Ring Joint	Round - Port, Full Bore - Long Pattern Ring Joint
API 2000 (13.8 MPa)			
2 1/16" x 1 13/16" (52x46)	295	-	-
2 1/16" (52)	295	333	-
2 9/16" (65)	333	384	-
3 1/8" (78)	359	448	-
4 1/16" (103)	435	511	-
5 1/8" (130)	-	638	-
7 1/16" x 6" (179x152)	562	727	-
7 1/16" (179)	-	740	-
API 3000 (20.7 MPa)			
2 1/16" x 1 13/16" (52x46)	371	-	-
2 1/16" (52)	371	384	-
2 9/16" (65)	422	435	-
3 1/8" (78)	384	473	-
4 1/16" (103)	460	562	-
5 1/8" (130)	-	664	-
7 1/16" x 6" (179x152)	613	765	-
7 1/16" (179)	-	803	-
API 5000 (34.5 MPa)			
2 1/16" x 1 13/16" (52x46)	371	-	-
2 1/16" (52)	371	394	-
2 9/16" (65)	422	457	-
3 1/8" (78)	473	527	-
4 1/16" (103)	549	629	-
7 1/16" x 6" (179x152)	711	-	-
7 1/16" (179)	-	978	-
API 10000 (69.0 MPa)			
1 13/16" (46)	-	464	-
2 1/16" (52)	-	521	-
2 9/16" (65)	-	565	-
3 1/16" (78)	-	619	-
4 1/16" (103)	-	670	-
5 1/16" (130)	-	737	-
7 1/16" x 6 3/8" (179x162)	-	889	-
7 1/16" (179)	-	889	-
API 15000 (103.4 MPa)			
1 13/16" (46)	-	457	-
2 1/16" (52)	-	483	597
2 9/16" (65)	-	533	635
3 1/16" (78)	-	598	-
4 1/16" (103)	-	737	-
5 1/8" (130)	-	889	-

Tolerance: +/-2 mm.



Qualification of other Size Valves - API 6FA

Size of Test Valve			
NPS	DN	NPS	DN
2 API 6D 1 ^{13/16} - 2 ^{1/16} API 6A	50	2 - 2 ^{1/2} - 3 - 4 API 6D 1 ^{13/16} - 2 ^{1/16} - 2 ^{9/16} - 3 ^{1/8} - 4 ^{1/16} API 6A	50 - 65 80 - 100
2 ^{9/16} API 6A 2 ^{1/2} API 6D	65	2 ^{9/16} - 3 ^{1/8} - 4 ^{1/16} - 5 ^{1/8} API 6A 2 ^{1/2} - 3 - 4 API 6D	65 - 80 100 - 125
3 API 6D 3 ^{9/16} API 6A	80	3 - 4 - 6 API 6D 3 ^{1/8} - 4 ^{1/16} - 5 ^{1/8} - 7 ^{1/16} API 6A	80 - 100 125 - 150
4 API 6D 4 ^{1/16} API 6A	100	4 - 6 - 8 API 6D 4 ^{1/16} - 5 ^{1/8} - 7 ^{1/16} API 6A	100 - 125 150 - 200
6 API 6D 7 ^{1/16} API 6A	150	6 - 8 - 10 - 12 API 6D 7 ^{1/16} - 9 - 11 API 6A	150 - 200 250 - 300
8 API 6D	200	8 - 10 - 12 - 14 - 16 API 6D 9 - 11 API 6A	200 - 250 300 - 350 - 400
10 API 6D	250	10 through 20 API 6D - 11 API 6A	250 through 500
12 API 6D	300	12 through 24 API 6D	300 through 600
14 API 6D	350	14 through 28 API 6D	350 through 700
16 API 6D	400	16 and larger 24 API 6D	400 and larger

Qualification of other Pressure Rating Valves

Rating of Test Valve					
Class	PN	Bar	Class	PN	Bar
150 API 6D	20	N/A	150 - 300 API 6D	20 - 50	N/A
300 API 6D	50	N/A	300 - 400 - 600 API 6D	50 - 64 - 110	N/A
400 API 6D	64	N/A	400 - 600 API 6D	64 - 110	N/A
600 API 6D	110	N/A	600 - 900 API 6D 2000 - 3000 API 6A	110 - 150 N/A	N/A 138 - 207
900 API 6D	150	N/A	900 - 1500 API 6D 3000 API 6A	150 - 260 N/A	N/A 207
1500 API 6D	260	N/A	1500 - 2500 API 6D 5000 API 6A	260 - 420 N/A	N/A 345
2500 API 6D	420	N/A	2500 API 6D 10000 API 6A	420 N/A	N/A 690
2000 API 6A	-	138	2000 - 3000 API 6A 900 - 1500 API 6D	N/A 150 - 260	138 - 207 N/A
3000 API 6A	-	207	3000 - 5000 API 6A 1500 - 2500 API 6D	N/A 260 - 420	207 - 345 N/A
5000 API 6A	-	345	5000 - 10000 API 6A 2500 API 6D	N/A 420	345 - 690 N/A
10000 API 6A	-	690	10000 - 15000 20000 API 6A	N/A	690 - 1034 1379



Plug Valves Application

GAS PIPELINES & COMPRESSOR - STATION

OFF SHORE



Client: SAUDI ARAMCO
Location: Saudi Arabia Pipeline Project EWG-1 (East West Gas Pipeline)
Supply of sales gas from ABQAIQ-YANBU, Km.1170
Valves: 30" Class 600 RF

Client: SAIPEM - Italy
LGTS - Green Stream Gas Pipeline
Project Subsea Pig Launcher - Receiver
Valves: DN 31/8" API 5000.



Client: SOFRESID SAIPEM France
Location: Russia Pig Launcher "Beregovaya Compressor Station"
Valves: DN 2" - 4" - 8" - ANSI 2500.

Client: Egyptian Natural Gas Co.
Gas Pipeline
Location: Egypt
Valves: 12" Class 600 RF

Client: SASOL - Nigel
High Integrity Pressure
Protection Station
Valve: 16" Class 300

Morinville, Alberta, Canada
Compression Station
Valves: 8"-12" ANSI 900.

Client: SNAMPROGETTI
Location: LOSTORF (CH)
Valve: 20" Cl. 600 Venturi with
Stem Extension.





GALLI&CASSINA in the World:

Our products are being used in the most important Plants and Gas Pipelines all over the world.

Galli&Cassina Plug Valves are used in the most important hydrocarbon plants and gas pipelines all over the world.

For over 70 years Galli&Cassina has been committed to provide service to the end-users with a full range of products ensuring total customer's satisfaction.

Galli&Cassina is represented by sales offices worldwide and you are requested to contact our main office in Italy for more details.





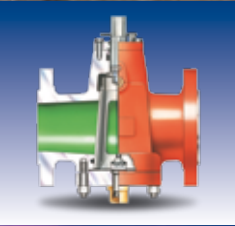
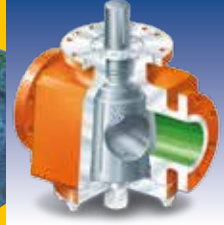
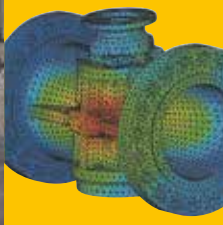

AdverTime-MI

G&C B10-2014



GALLI&CASSINA

Plus Valves SINCE 1919

Office and Workshop:

GALLI&CASSINA S.p.A.

Via Drizza, 30/32 • 20020 SOLARO (MILANO) Italy
Phone: + 39.02.96799632/3 • Telefax: + 39.02.96799699
<http://www.gallicassina.it> • E-mail: valves@gallicassina.it

