

GWC ITALIA

Proven technology
for individual valve solutions
worldwide



**API 6D SWING
CHECK VALVES**

SC-1002



GWC ITALIA

Worldwide Network

ITALY GROUP HEADQUARTERS, MANUFACTURING & SALES

GWC Italia S.p.A.
Via A. Grandi, 5
20056 Trezzo Sull'Adda
Milano, Italy
Phone: +39 02 86882941
Fax: +39 02 86882942
Email: sales@gwcitalia.com



**USA HEADQUARTERS
MANUFACTURING & SALES**
GWC Italia
8502 Crippen Street
Bakersfield, USA 93311
Phone: +1 661 834 1775
Fax: +1 661 834 2072
Email: sales@gwcitalia-usa.com



SALES DUBAI
GWC Italia DMCC
1506, Platinum Tower
I-Cluster,
Jumeirah Lake Towers
Dubai UAE
Phone: +971 44 539 358
Email: sales@gwcitalia.com



MANUFACTURING & SALES
GWC Valve Manufacturing
(Shanghai) Co., Ltd.
No 3300 Tianchen Road,
Qingpu, Shanghai 201708,
China
Phone: +86 21 5979 8796
Fax: +86 21 5979 8790
Email: sales@gwcitalia.com

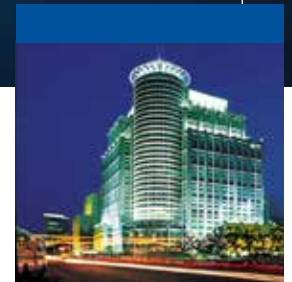

SALES CHINA
GWC Italia
5/F, China Life Tower, No.16
Chaowai Street
Chaoyang District
Beijing 100020, China
Phone: +86 10 5877 1065
Fax: +86 10 5877 1120
Email: sales@gwcitalia.com

GWC Italia SpA with its Headquarters in Milan, Italy fully designs, manufactures and markets valves with one of the most extensive Trunnion Mounted Ball Valve lines you will find in the Industry today. GWC Italia which was founded by an Italian Group & USA Entrepreneurial Management team has a history of building and managing successful valve Manufacturing companies over the past 40 years. GWC Italia Valves are used in major applications for Upstream, Downstream & Transportation Segments of the Oil & Gas Industry, E&P, Petrochemical, Chemical, Mining/Minerals, Power, Marine and Industrial markets.

GWC Italia's extensive line of valve and flow control products include:

- Trunnion Mounted Ball Valves (soft & metal seated)
 - Split Body
 - Top Entry
 - Welded Body
 - Subsea
 - Cryogenic & High Temperature
 - Compact Body (Twin Ball)
- Floating Ball Valves
- Pipeline Gate and Check Valves
- Gate, Globe and Check Valves including Cast & Forged
- Needle & Gauge Valves



**Proven technology
for individual valve solutions
worldwide**

CERTIFICATIONS & STANDARDS

American Standards

American Petroleum Institute

API-6D	Specification for Pipeline Valves
API-6D SS	Specification for Subsea Pipeline Valves
API-6A	Specification for Wellhead and Christmas Tree Equipment
API-6FA	Specification for Fire Test for Valves
API-598	Valve Inspection and Testing
API-600	Bolted Bonnet Steel Gate Valves for Petroleum and Natural Gas Industries
API-602	Compact Steel Gate Valves-Flanged, Threaded, Welding and Extended-Body Ends
API-607	Fire Test for Soft-Seated Quarter-Turn Valves
API-608	Metal Ball Valves - Flanged, Threaded, and Welding End
API-Q1	Specification for Quality Programs for the Petroleum, Petrochemical & Natural Gas

International Standards

ISO 9001	Quality Management Systems
ISO 14001	Environmental Management
OHSAS 18001	Occupational Health and Safety Management System
ISO/TS 29001	Petroleum, Petrochemical and Natural Gas Industries - Sector Specific Quality Management Systems
CE/PED	Pressure Equipment Directive
TR CU	Technical Regulations of the Customs Union
CRN	Canadian Registration Number
Z245.15-17	Steel Valves
ATEX	European for explosive atmosphere
SIL3	Measurement of performance required for safety instrument function
ABS	American Bureau of Shipping



SWING CHECK VALVE STANDARD FEATURES

Model 83 Flanged Swing Check Valves

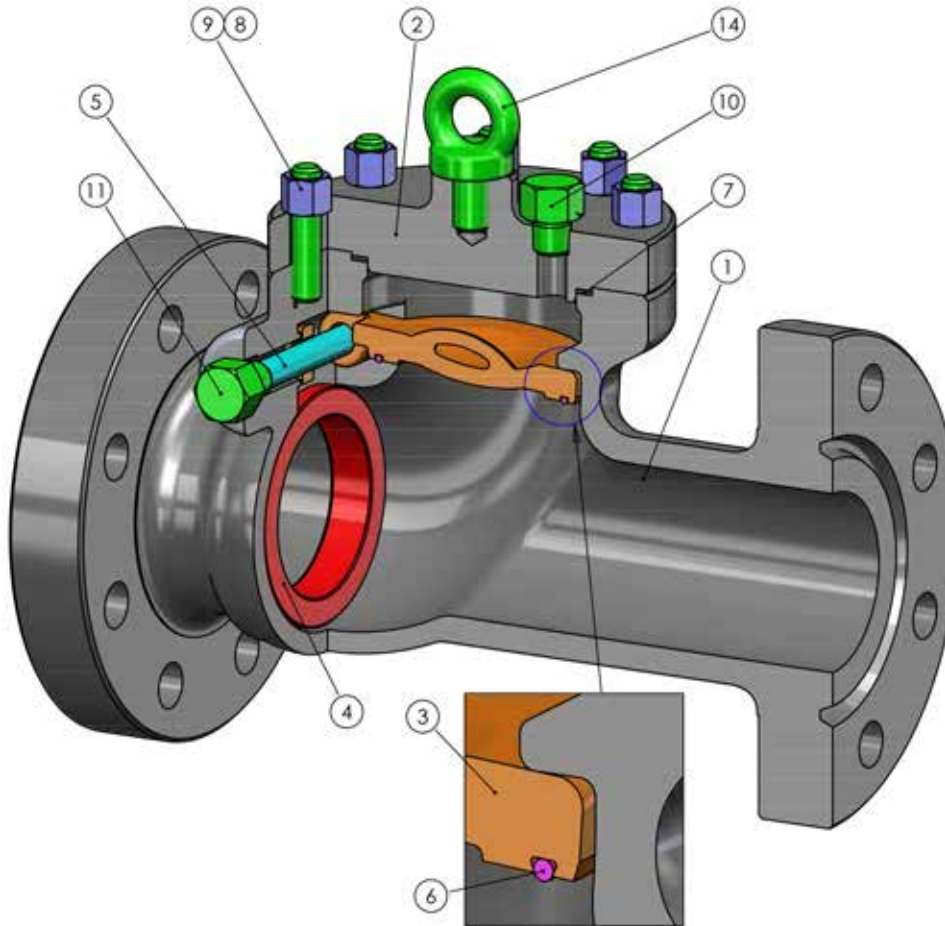

Standard Features

- Full Open Piggable Design for low pressure drop and less turbulence
- API-6D Monogram
- All materials conform to NACE MR0175
- 316 Stainless Steel trim is compatible with a broad range of media and operating conditions
- Suitable for Vertical flow up or Horizontal installation
- Bolted top entry with 1/2" NPT bleed plug on cover
- 90 durometer seals are standard
- Seals provide a bubble tight shutoff
- In-line repairable

STANDARD PARTS AND MATERIALS

ITEM	PART NAME	STANDARD TRIM (Sour Service - NACE)	LOW TEMPERATURE TRIM (Sour Service - NACE)
1	Body	ASTM A216 Gr.WCB	ASTM A352 Gr.LCC
2	Cover	ASTM A105N/ASTM A216 Gr.WCB	ASTM A350 Gr.LF2 / ASTM A352 Gr.LCC
3	Clapper	ASTM A351 Gr.CF8M	ASTM A351 Gr.CF8M
4	Seat Ring	ASTM A182 Gr.F316	ASTM A182 Gr.F316
5	Clapper Pin	ASTM A182 Gr.F316	ASTM A182 Gr.F316
6	Clapper O-Ring	HNBR	HNBR
7	Cover Gasket	Spiral Wound Graphite+316SS	Spiral Wound Graphite+316SS
8	Stud	ASTM A193 Gr.B7M	ASTM A320 Gr.L7M
9	Nut	ASTM A194 Gr.2HM	ASTM A194 Gr.L7M
10	Vent Plug	Carbon Steel	Carbon Steel
11	Hinge Pin Plug	Carbon Steel	Carbon Steel
12	Name Plate	SS304	SS 304
13	Hinge Pin Washer	ASTM A276 Gr.420	ASTM A276 Gr.420
14	Eyebolt	Carbon Steel (2" and above for class 600-2500) 4" and above for class 150-300)	Carbon Steel (2" and above for class 600-2500) 4" and above for class 150-300)

* We reserve the right to make changes to materials and specifications.

ORDERING GUIDE

EXAMPLE: 8", FIGURE #83 90 0-BC-1

83	90	0	-	BC	-	1
1.	2.	3.		4.		5.

8" CLASS 900 API 6D FULL OPENING SWING CHECK VALVE, RF FLANGED,
A216 WCB BODY/CAP, 316 SS TRIM, HNBR O RINGS, NACE MR-0175.

1. MODEL

83 – API 6D SWING CHECK VALVE REPLACEABLE SEAT
84 – API 6D SWING CHECK VALVE INTEGRAL SEAT

2. RATING

15 – CLASS 150	90 – CLASS 900
30 – CLASS 300	150 – CLASS 1500
60 – CLASS 600	250 – CLASS 2500

3. END CONNECTION

0 – RF FLANGED	9 – RING JOINT
7 – BUTTWELD (SCHEDULE REQUIRED)	X – SPECIAL
8 – BUTTWELD X RF FLANGED	

4. MATERIAL (BODY + COVER) + TRIM

BC – WCB + 316	GC – LCC + 316
DC – WCB + 13CR (410 SS)	LC – CF8M + 316
FC – LCC + 13 CR (410 SS)	X – SPECIAL

5. MATERIAL (O RING)

1 – HNBR	5 – AFLAS
2 – VITON-B	6 – BUNA – N
3 – VITON – GLT	7 – METAL TO METAL
4 – EPDM	8 – SPECIAL

6. SPECIAL REQUIREMENTS

O – OUTSIDE WEIGHT & LEVER
S – SUPPLY COMPLETE INFORMATION

MODEL 83150 / 83157 / 83159

Cast steel swing check valve, horizontal or vertical lines, bolted cover, available in renewable seat rings, designed according to API-6D.

DIMENSIONS

Face to Face	API-6D
End Flange	ASME B16.5"
Buttweld	ASME B16.25"
Rating	ASME Class 150

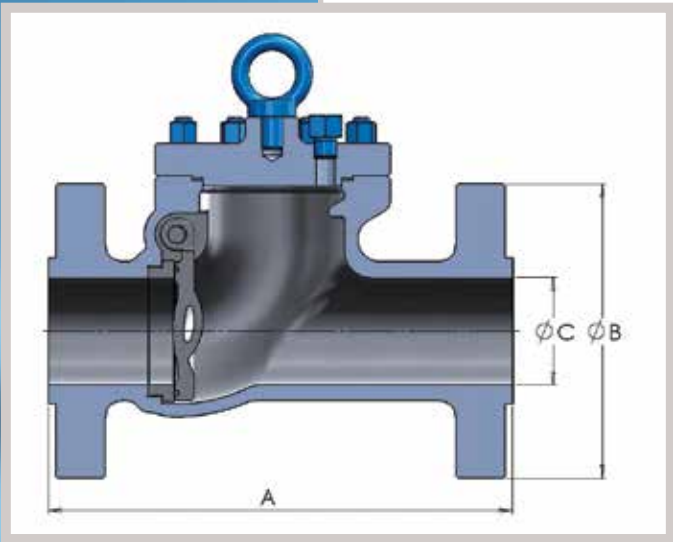

CLASS 150

VALVE SIZE		2" 50 mm	3" 80 mm	4" 100 mm	6" 150 mm	8" 200 mm	10" 250 mm	12" 300 mm	14" 350 mm	16" 400 mm	18" 450 mm	20" 500 mm	24" 600 mm	26" 650 mm	30" 750 mm	36" 900 mm
Face-to-Face	RF	8	9.5	11.5	14	19.5	24.5	27.5	31	34	38.5	38.5	51	51	60	77
	RTJ	8.5	10	12	14.5	20	25	28	31.5	34.5	39	39	51.5	-	-	
	BW	8	9.5	11.5	14	19.5	24.5	27.5	31	34	38.5	38.5	51	51	60	77
Valve Height (H)		5.5	5.5	7.0	11.0	13.0	1.0	17.1	17.2	18.9	21.0	22.6	24.2	27.0	31.0	36.5
Weight (lbs)	RF	41.9	66.1	92.6	185.1	330.6	506.9	731.7	811.1	1080.0	1392.9	1864.6	3019.5	3195.8	4672.5	6567.9
	BW	30.9	48.5	66.1	158.7	304.2	410.1	577.6	740.8	937.0	1194.9	1664.5	2623.5	2976.2	4034.5	5908.4

MODEL 83300 / 83307 / 83309

Cast steel swing check valve, horizontal or vertical lines, bolted cover, available in renewable seat rings, designed according to API-6D.

DIMENSIONS

Face to Face	API 6D
End Flange	ASME B16.5
Buttweld	ASME B16.25
Rating	ASME Class 300

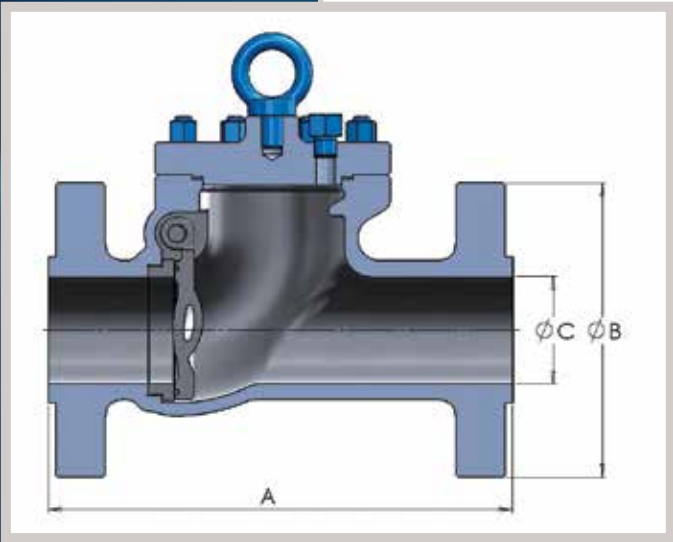

CLASS 300

VALVE SIZE		2" 50 mm	3" 80 mm	4" 100 mm	6" 150 mm	8" 200 mm	10" 250 mm	12" 300 mm	14" 350 mm	16" 400 mm	18" 450 mm	20" 500 mm	24" 600 mm	26" 650 mm	30" 750 mm	36" 900 mm
Face-to-Face	RF	10.5	12.5	14	17.5	21	24.5	28	33	34	38.5	40	53	53	62.75	82
	RTJ	11.13	13.13	14.63	18.13	21.63	25.13	28.63	33.63	34.63	39.13	40.75	53.88	54	63.75	-
	BW	10.5	12.5	14	17.5	21	24.5	28	33	34	38.5	40	53	53	62.75	82
Valve Height (H)		5.8	7.5	8.3	11.1	12.3	15.2	17.0	18.2	20.8	23.3	25.1	28.3	30.1	34.1	40.1
Weight (lbs)	RF	22	42	71	127	212	297	370	490	615	735	980	1815	2115	2460	4730
	BW	19	30	52	102	187	258	320	410	530	682	790	1605	2005	2130	4100

MODEL 83600 / 83607 / 83609

Cast steel swing check valve, horizontal or vertical lines, bolted cover, available in renewable or integral seat rings, designed according to API-6D.

DIMENSIONS

Face to Face	API-6D
End Flange	ASME B16.5
Buttweld	ASME B16.25
Rating	ASME Class 600

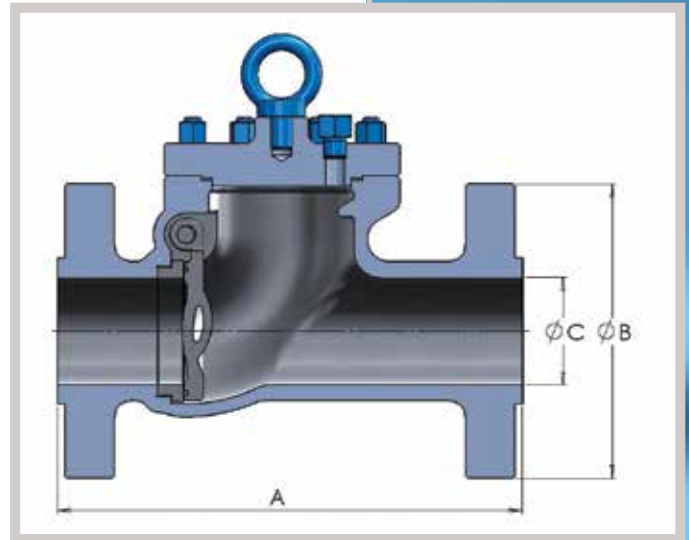

CLASS 600

VALVE SIZE		2" 50 mm	3" 80 mm	4" 100 mm	6" 150 mm	8" 200 mm	10" 250 mm	12" 300 mm	14" 350 mm	16" 400 mm	18" 450 mm	20" 500 mm	24" 600 mm	26" 650 mm	30" 750 mm	36" 900 mm
Face-to-Face	RF	11.5	14	17	22	26	31	33	35	39	43	47	55	57	65	82
	RTJ	11.63	14.13	17.13	22.13	26.13	31.131	33.13	35.13	39.13	43.13	47.25	51.38	57.5	65.5	-
	BW	11.5	14	17	22	26	31	33	35	39	43	47	55	57	65	82
Valve Height (H)		6.1	7.4	8.6	12.6	13.3	16.5	18.6	20.9	25.3	26.3	28.4	31.6	40.4	34.6	37.7
Weight (lbs)	RF	36	61	116	217	420	570	788	1020	1440	1695	2600	3600	4715	5880	10450
	BW	28	50	90	182	360	460	665	865	1200	1430	2230	3085	4310	5420	9600

MODEL 83900 / 83907 / 83909

Cast steel swing check valve, horizontal or vertical lines, bolted cover, available in renewable seat rings, designed according to API-6D.

DIMENSIONS

Face to Face	API-6D
End Flange	ASME B16.5
Buttweld	ASME B16.25
Rating	ASME Class 900

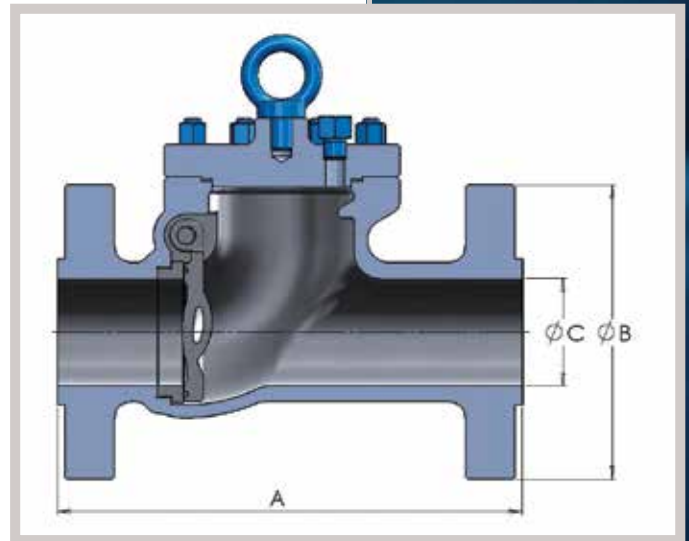

CLASS 900

VALVE SIZE		2" 50 mm	3" 80 mm	4" 100 mm	6" 150 mm	8" 200 mm	10" 250 mm	12" 300 mm	14" 350 mm	16" 400 mm	18" 450 mm	20" 500 mm	24" 600 mm	26" 650 mm	30" 750 mm	36" 900 mm
Face-to-Face	RF	14.5	15	18	24	29	33	38	40.5	44.5	48	52	61	-	-	-
	RTJ	14.63	15.13	18.13	24.13	29.13	33.13	38.13	40.88	44.88	48.5	52.5	61.75	-	-	-
	BW	14.5	15	18	24	29	33	38	40.5	44.5	48	52	61	-	-	-
Valve Height (H)		-	6.6	7.9	15.3	16.3	18.0	19.8	22.5	26.0	27.8	30.4	35.3	-	-	-
Weight (lbs)	RF	76	82	160	272	548	944	1560	1660	2060	3020	3750	5400	-	-	-
	BW	62	68	135	215	446	840	1370	1440	1780	2340	2900	4210	-	-	-

MODEL 831500 / 831507 / 831509

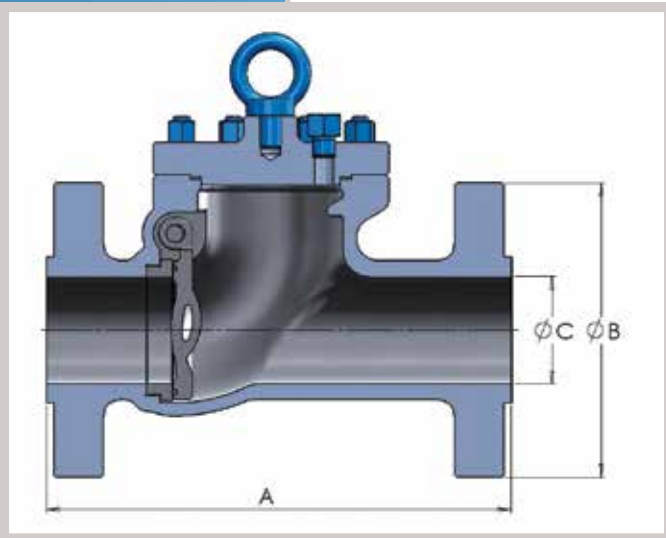

Cast steel swing check valve, horizontal or vertical lines, bolted cover, available in renewable seat rings, designed according to API-6D.

DIMENSIONS

Face to Face	API-6D
End Flange	ASME B16.5
Buttweld	ASME B16.25
Rating	ASME Class 1500

CLASS 1500

VALVE SIZE		2" 50 mm	3" 80 mm	4" 100 mm	6" 150 mm	8" 200 mm	10" 250 mm	12" 300 mm	14" 350 mm	16" 400 mm	18" 450 mm	20" 500 mm	24" 600 mm	26" 650 mm	30" 750 mm	36" 900 mm
Face-to-Face	RF	14.5	18.5	21.5	27.5	32.75	39	44.5	49.5	54.5	60.5	65.5	76.5	-	-	-
	RTJ	14.63	18.63	21.63	28	33.13	39.38	45.13	50.25	55.38	61.38	66.38	77.63	-	-	-
	BW	14.5	18.5	21.5	27.5	32.75	39	44.5	49.5	54.5	60.5	65.5	76.5	-	-	-
Valve Height (H)		7.2	9.8	11.6	13.4	15.5	17.8	20.2	22.3	24.5	27.0	29.2	34.0	-	-	-
Weight (lbs)	RF	76	128	230	506	942	1750	2350	2950	3600	5500	6800	10150	-	-	-
	BW	62	105	205	456	843	1500	2020	2400	3015	4680	5600	8150	-	-	-

MODEL 83900 / 83907 / 83909

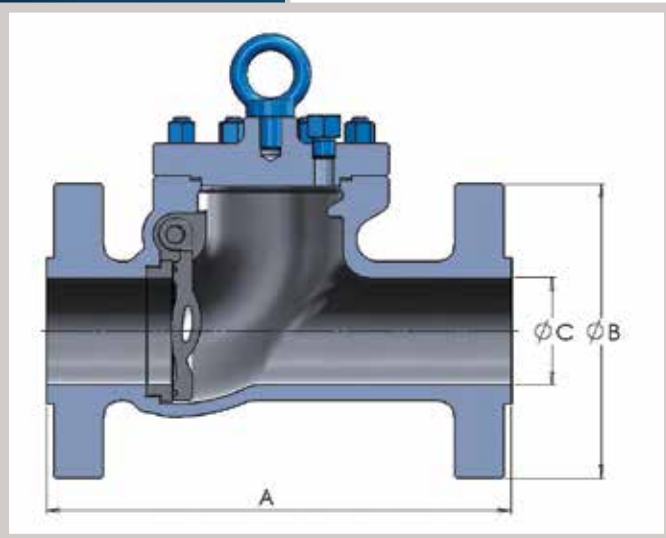

Cast steel swing check valve, horizontal or vertical lines, bolted cover, available in renewable seat rings, designed according to API-6D.

DIMENSIONS

Face to Face	API-6D
End Flange	ASME B16.5
Buttweld	ASME B16.25
Rating	ASME Class 2500

CLASS 2500

VALVE SIZE		2" 50 mm	3" 80 mm	4" 100 mm	6" 150 mm	8" 200 mm	10" 250 mm	12" 300 mm	14" 350 mm	16" 400 mm	18" 450 mm	20" 500 mm	24" 600 mm	26" 650 mm	30" 750 mm	36" 900 mm
Face-to-Face	RF	17.75	22.75	26.5	36	40.25	50	56	-	-	-	-	-	-	-	-
	RTJ	17.88	23	26.88	36.5	40.88	50.88	56.88	-	-	-	-	-	-	-	-
	BW	17.75	22.75	26.5	36	40.25	50	56	-	-	-	-	-	-	-	-
Valve Height (H)		10.7	12.2	15.2	17.1	19.6	22.5	27.1	-	-	-	-	-	-	-	-
Weight (lbs)	RF	145	260	480	1020	1700	3110	3700	-	-	-	-	-	-	-	-
	BW	110	185	430	830	1280	2410	2600	-	-	-	-	-	-	-	-



**WORLDWIDE
HEADQUARTERS**

GWC Italia S.p.A.

Via A. Grandi, 5
20056 Trezzo Sull'Adda
Milano, Italy

Phone: +39 02 86882941

Fax: +39 02 86882942

USA HEADQUARTERS

GWC Italia

8502 Crippen Street
Bakersfield, CA 93311

Phone: +1 661 834 1775

Fax: +1 661 834 2072

www.gwcitalia.com