

Building connections that last™



S2 QVA

Seal Welded Steel Ball Valve Datasheet



Seal Welded Steel Ball Valve S2 QVA

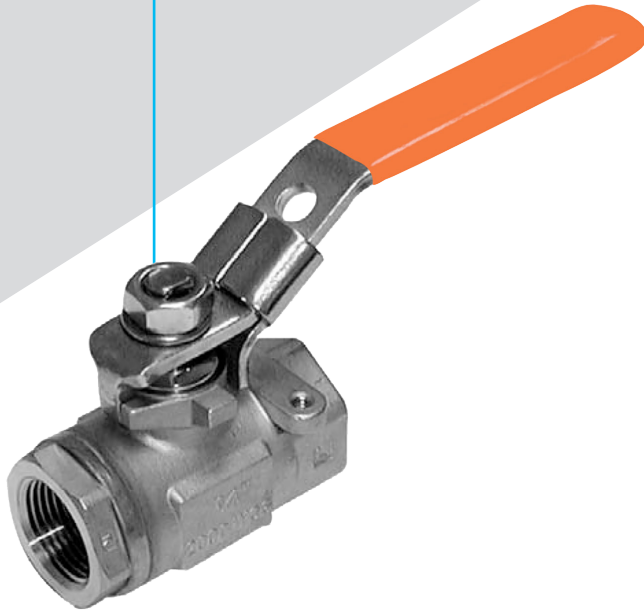

Features

- One Piece – Seal Welded Construction
- 2000 WOG Rating on All Sizes
- 150 PSIG Saturated Steam Rating
- All Models are NACE MR-01-75 Compliant
- CF8M or WCB Bodies and Tailpieces, 316 Stainless Steel Internals
- Available in Full, Alloy-20 (CN7M) Construction
- Available in Male x Female Construction in 1/4"–1" Sizes
- Standard Actuator Mounting Pads on all Sizes
- Standard Stainless Steel Locking Handles
- Locking Oval Handles Available in Stainless Steel
- The Ultimate in Safe Design!

Ratings

2000 PSIG @100°F Water, Oil, Gas
150 PSIG Saturated Steam

Materials of Construction

Part	Description	Standard Material	Optional Material(s)
1	Body	ASTM A351 Gr. CF8M or A216 Gr. WCB	
2	Tailpiece	ASTM A351 Gr. CF8M or A216 Gr. WCB	
3	Ball	ASTM A276 Gr. 316	
4	Stem	ASTM A276 Gr. 316	
5	Packing Nut	ASTM A276 Gr. 316	
6	Seats (2)	R-PTFE	Steam Seats, PEEK
7	Packing	R-PTFE	Graphite, PEEK
8	Thrust Washer	R-PTFE	PEEK
9	Handle Assy	Stainless Steel w/Vinyl	Stainless Locking Oval
10	Handle Nut	Stainless Steel	

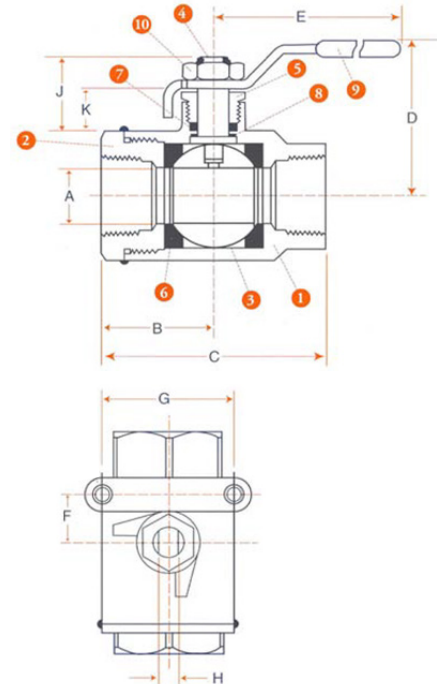

Seal Welded Steel Ball Valve S2 QVA

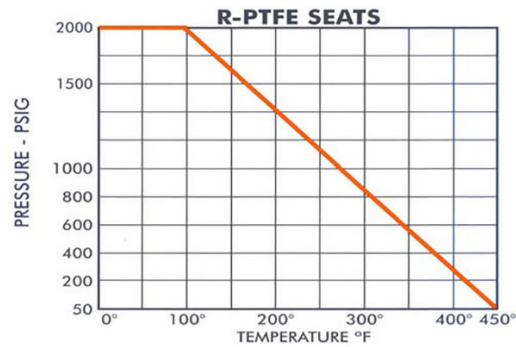
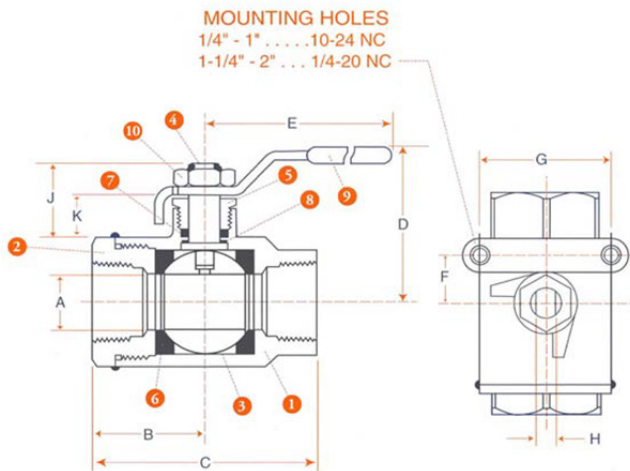

Dimensions, Weights, Cv Factors & Maximum Operating Torque

Size	A	B	C	D	E	F	G	H	J	K	Weight Lbs.	CV	Max Torque
1/4"-3/8"	0.38	1.1	2.2	1.8	4.4	0.50	1.12	0.20	0.86	0.50	0.50	9	40 IN-LB
1/2"	0.50	1.2	2.4	2.0	4.4	0.50	1.12	0.20	0.96	0.55	0.66	16	75 IN-LB
3/4"	0.69	1.4	2.8	2.4	5.9	0.87	1.38	0.28	1.32	0.71	1.32	27	120 IN-LB
1"	0.87	1.6	3.2	2.6	5.9	0.87	1.38	0.28	1.31	0.70	1.81	42	140 IN-LB
1-1/4"	1.0	1.8	3.6	2.8	7.8	0.93	1.50	0.35	1.42	0.76	2.51	52	250 IN-LB
1-1/2"	1.3	2.1	4.1	3.0	7.8	0.93	1.50	0.35	1.42	0.76	3.74	80	300 IN-LB
2"	1.5	2.3	4.6	3.2	7.8	0.93	1.50	0.35	1.42	0.77	5.53	115	320 IN-LB

Numbering System How to order S2 QVA

S2	R	S	S	R	R	SL	TT	100
Series	Port Size	Body Material	Ball/Stem Material	Seat Material	Seal Material	Handle Type	Ends	Size
S2 Seal Welded 2000WOG	F Full (1/4"-1/2")	S Stainless (CF8M)	S 316 Stainless	R R-PTFE	R R-PTFE	SL Stainless Latch Lock	TT FNPT	025 1/4"
	R Reduced (3/4"-2")	C Carbon (WCB)		P Peek	P Peek	SO Stainless Oval	MT MxF NPT	038 3/8"
				Z Steam Seats	G Graphite	LO Stainless Locking Oval		050 1/2"
						PA Double Acting Pneumatic		075 3/4"
						SA Spring Return Pneumatic		100 1"
						SR Deadman Handle		125 1-1/4"
								150 1-1/2"
								200 2"

About ASC Engineered Solutions

ASC Engineered Solutions is defined by quality—in its products, services and support. With more than 1,400 employees, the company's portfolio of precision-engineered piping support, valves and connections provides products to more than 4,000 customers across industries, such as mechanical, industrial, fire protection, oil and gas, and commercial and residential construction. Its portfolio of leading brands includes ABZ Valve®, AFCON®, Anvil®, Anvil EPS, Anvil Services, Basic-PSA, Beck®, Catawissa, Cooplet®, FlexHead®, FPPI®, Gruklok®, J.B. Smith, Merit®, North Alabama Pipe, Quadrant®, SCI®, Sharpe®, SlideLOK®, SPF® and SprinkFLEX®. With headquarters in Commerce, CA, and Exeter, NH, ASC also has ISO 9001:2015 certified production facilities in PA, TN, IL, TX, AL, LA, KS, and RI.



asc-es.com

Building connections that last™

FC-DS-S2 QVA-v01 20210524

