

Building connections that last™

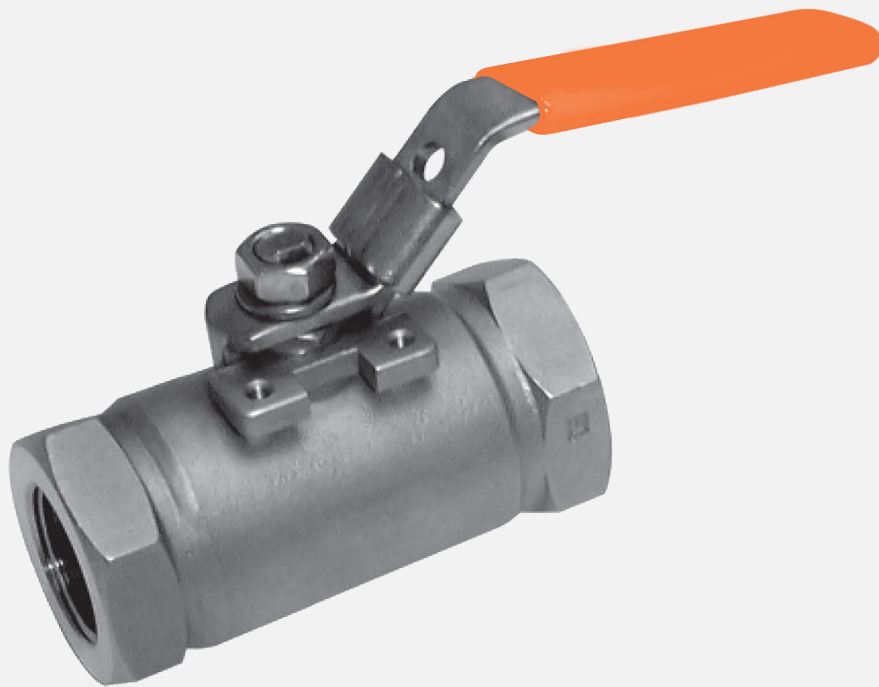

S5 QVA

Seal Welded High Pressure Ball Valves Datasheet



Seal Welded High Pressure Ball Valves

S5 QVA

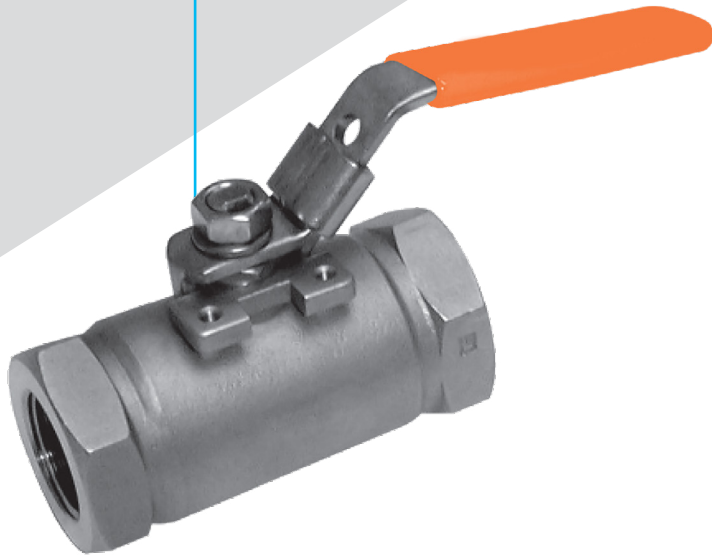

Features

- Seal Welded Construction
- Full Port and Reduced Port Versions Available
- All Stainless Construction – CF8M Bodies
- Tailpieces, 316SS Internals
- 5000 WOG Rating on All Sizes
- Delrin Seats Standard
- All Models are NACE MR0175 Compliant
- All Models are API 607 Fire Safe
- Standard ISO Actuator Mounting Pads on all Sizes
- Standard Locking Stainless Steel Handles
- The Ultimate Valve for Safe High Pressure Service
- API 641 Certified

Ratings

5000 PSIG @100°F Water, Oil, Gas

No steam service rating (Delrin seats)

Materials of Construction

Part	Description	Standard Material
1	Body	ASTM A351 GR. CF8M
2	Tailpiece	ASTM A351 GR. CF8M
3	Ball	ASTM A276 GR. 316 SS
4	Stem	316SS or 17-4PH (1-1/2-2")
5	Packing Nut	ASTM A276 GR. 316 SS
6	Seats (2)	Delrin 100AF
7	Tailpiece Seal	Graphite
8	Thrust Washer	PTFE
9	Stem Packing	Graphite
10	Lock Washer	304 SS
11	Handle Nut	304 SS
12	Handle Assy	304 SS

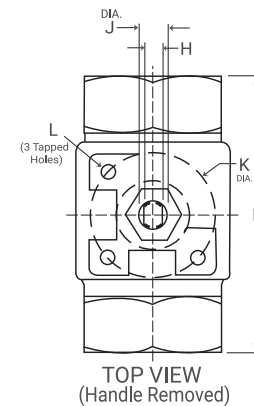
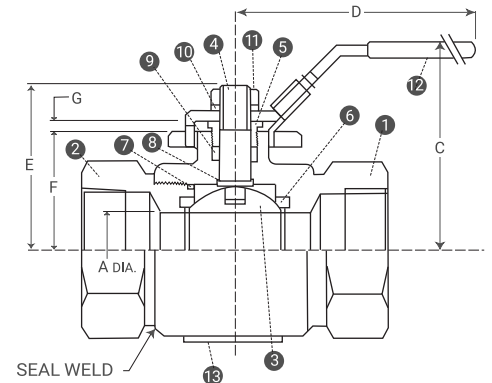

Seal Welded High Pressure Ball Valves

S5 QVA

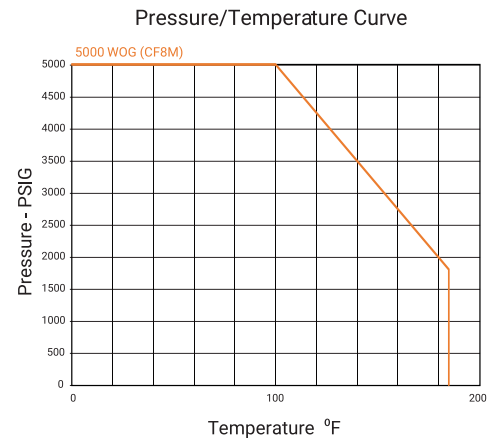
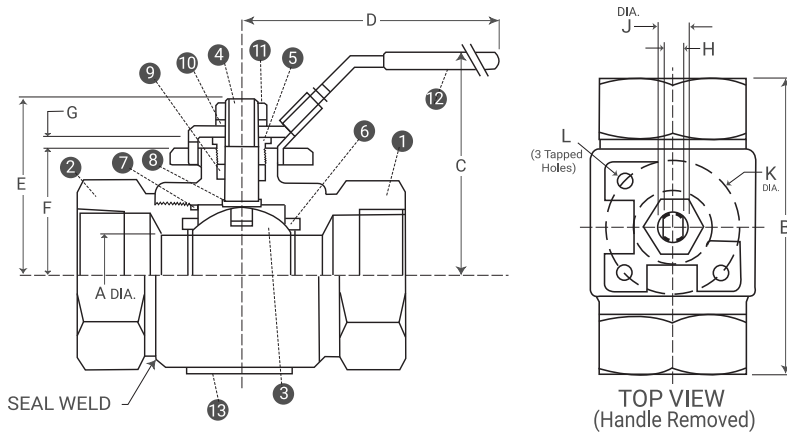

Dimensions, Weights, Cv Factors & Maximum Operating Torque

Size	A	B	C	D	E	F	G	H	J	K	L (3 TAPPED HOLES)	ISO Pattern	Weight Lbs.	CV	Max Torque
¼" FP	0.25	3.0	2.28	4.94	1.63	.97	0.34	.20	0.31	1.42	¼"-20 UNC	F03	1.6	10	75 IN-LB
½" FP	0.5	4.0	2.28	4.94	1.63	.97	0.34	.20	0.31	1.42	¼"-20 UNC	F03	1.6	16	75 IN-LB
¾" FP	0.75	4.25	2.80	5.57	2.22	1.29	0.42	0.28	0.43	1.65	¼"-20 UNC	F04	2.7	32	120 IN-LB
1" RP	0.75	4.25	2.80	5.57	2.22	1.29	0.42	0.28	0.43	1.65	¼"-20 UNC	F04	3.0	44	200 IN-LB
1" FP	1.0	4.49	3.70	7.20	2.79	1.65	0.43	0.35	0.56	1.97	¼"-20 UNC	F05	6.2	62	400 IN-LB
1-½" FP	1.5	5.29	4.60	13.85	3.87	2.51	0.50	0.39	0.62	2.76	⅝"-18 UNC	F07	11.3	140	750 IN-LB
2" RP	1.5	6.25	4.60	13.85	3.87	2.51	0.50	0.39	0.62	2.76	⅝"-18 UNC	F07	11.7	120	750 IN-LB

Numbering System How to order S5 QVA

S5	F	S	S	A	F	SL	TT	050
Series	Port Size	Body Material	Ball/Stem Material	Seat Material	Seal Material	Handle Type	Ends	Size
S5 Seal Welded 5000 WOG	R Reduced	S Stainless (CF8M)	S 316 Stainless	A ACETAL (Delrin)	F Graphite	SL Stainless Latch Lock	TT FNPT	025 ¼"
	F Full					LO Locking Stainless Oval		038 ⅜"
						PA Double Acting Pneumatic		050 ½"
						SA Spring Return Pneumatic		075 ¾"
								100 1"
								150 1-½"
								200 2"

About ASC Engineered Solutions

ASC Engineered Solutions is defined by quality—in its products, services and support. With more than 1,400 employees, the company's portfolio of precision-engineered piping support, valves and connections provides products to more than 4,000 customers across industries, such as mechanical, industrial, fire protection, oil and gas, and commercial and residential construction. Its portfolio of leading brands includes ABZ Valve®, AFCON®, Anvil®, Anvil EPS, Anvil Services, Basic-PSA, Beck®, Catawissa, Cooplet®, FlexHead®, FPPI®, Grevlok®, J.B. Smith, Merit®, North Alabama Pipe, Quadrant®, SCI®, Sharpe®, SlideLOK®, SPF® and SprinkFLEX®. With headquarters in Commerce, CA, and Exeter, NH, ASC also has ISO 9001:2015 certified production facilities in PA, TN, IL, TX, AL, LA, KS, and RI.



asc-es.com

Building connections that last™

FC-DS-S5 QVA-v01 20210524

